

Numerical Methods for Hamiltonian PDEs

Thomas J. Bridges* Sebastian Reich†

February 13, 2006

Contents

1	Introduction and overview	1
2	From Hamiltonian ODEs to Hamiltonian PDEs	4
2.1	Finite-Dimensional Hamiltonian Systems	4
2.2	Infinite-Dimensional Hamiltonian Systems	7
2.3	Multi-Symplectic Hamiltonian PDEs	10
3	Semi-Discretization and the Method of Lines	12
3.1	Discrete Hamiltonian Approach	12
3.2	Discrete Lagrangian Approach	13
4	Implicit Time-Stepping and Regularized PDEs	15
4.1	Rothe’s Method and the Implicit Midpoint Time Discretization	15
4.2	Linear Analysis of the Implicit Midpoint Method	16
4.3	Equivalent Leapfrog Time-Stepping for Regularized Shallow-Water Equations	18
5	Variational Integrators and the Cartan Form	20
6	Discretizing Multi-Symplectic Hamiltonian PDEs	21
6.1	Discrete Energy and Momentum Conservation	24
6.2	Analysis of the Discretized Dispersion Relation	25
7	Multi-Symplectic Discretizations on the TEA Bundle	27

1 Introduction and overview

One of the great challenges in the numerical analysis of partial differential equations (PDEs) is the development of robust stable numerical algorithms for Hamiltonian PDEs. There is no shortage of motivation: Hamiltonian PDEs arise as models in meteorology and weather prediction, nonlinear optics, solid mechanics and elastodynamics, oceanography, electromagnetism, cosmology and quantum field theory, for example. It is now well known from the development of algorithms for Hamiltonian ODEs that ‘geometric integration’ is an important guiding principle. The geometric integration of

*Department of Mathematics, University of Surrey, Guildford, Surrey GU2 7XH England (e-mail: t.bridges@surrey.ac.uk)

†Institut für Mathematik, Universität Potsdam, Postfach 60 15 53, D-14415 Potsdam, Germany (e-mail: sreich@math.uni-potsdam.de)

Hamiltonian ODEs is now a well-developed subject with a range of fundamental results (cf. HAIRER, LUBICH & WANNER [61], LEIMKUHLER & REICH [85]).

There is a principal difficulty that arises when generalizing from Hamiltonian ODEs to Hamiltonian PDEs. The phase space goes from finite to infinite dimension or, on other words, the fields are parameterized by time and space. For illustration consider the semi-linear wave equation

$$u_{tt} = u_{xx} - f(u), \quad (1)$$

where $f(u)$ is a given smooth function, and the field $u(x, t)$ is scalar valued. By letting $v = u_t$ the wave equation (1) can be viewed as an infinite dimensional Hamiltonian system

$$\mathbf{J}\mathbf{u}_t = \frac{\delta H}{\delta \mathbf{u}}, \quad \mathbf{J} = \begin{bmatrix} 0 & -1 \\ 1 & 0 \end{bmatrix}, \quad \mathbf{u} = (u, v)^T, \quad \frac{\delta H}{\delta \mathbf{u}} = \left(\frac{\partial H}{\partial u}, \frac{\partial H}{\partial v} \right)^T. \quad (2)$$

The canonical coordinates (u, v) take values in a function space, for example a subspace of the L -periodic square-integrable functions. On the chosen function space, the symplectic form and Hamiltonian functional are

$$\Omega = \int_0^L dv \wedge du \, dx, \quad H(\mathbf{u}) = \int_0^L \left[\frac{1}{2}v^2 + \frac{1}{2}u_x^2 + F(u) \right] dx, \quad F'(u) = f(u).$$

Furthermore, $\delta H/\delta u$, $\delta H/\delta v$ denote functional derivatives of H with respect to u and v , respectively.

By taking a finite-mode approximation (say a finite Fourier series in x), the PDE is reduced to a Hamiltonian ODE for which a wide variety of numerical methods exist. In this setting the principle difficulty is proving – and understanding – the convergence as the number of modes tends to infinity.

The formulation (2) treats the space coordinate passively. The form of the spatial variation – periodic functions, say – is fixed. There are however many problems where it is advantageous to consider space and time on an equal footing. In this case one uses a multi-symplectic Hamiltonian formulation of (1)

$$\mathbf{K}\mathbf{z}_t + \mathbf{L}\mathbf{z}_x = \nabla S_{\mathbf{z}}(\mathbf{z}), \quad \mathbf{z} \in \mathbb{R}^4. \quad (3)$$

The 4×4 matrices \mathbf{K} and \mathbf{L} are skew-symmetric,

$$\mathbf{K} = \begin{bmatrix} 0 & 1 & 0 & 0 \\ -1 & 0 & 0 & 0 \\ 0 & 0 & 0 & 1 \\ 0 & 0 & -1 & 0 \end{bmatrix}, \quad \mathbf{L} = \begin{bmatrix} 0 & 0 & -1 & 0 \\ 0 & 0 & 0 & -1 \\ 1 & 0 & 0 & 0 \\ 0 & 1 & 0 & 0 \end{bmatrix}. \quad (4)$$

The gradient $\nabla S_{\mathbf{z}}(\mathbf{z})$ is the standard gradient on \mathbb{R}^4 , and S is the algebraic function

$$S(\mathbf{z}) = \frac{1}{2}v^2 - \frac{1}{2}w^2 + F(u) \quad \text{with} \quad \mathbf{z} = (u, v, w, \phi)^T.$$

Both the classical and the multi-symplectic Hamiltonian formulations have their merits when it comes to numerical discretization. The classical Hamiltonian formulations are well suited for the method of lines approach to the discretization of evolutionary PDEs. The method of lines approach typically leads to completely different discretizations in space and time.

On the other hand, multi-symplectic Hamiltonian formulations rely on local conservation laws and, hence, are well suited for numerical discretization methods that emphasize local properties. For example, the symplectic properties of interior points can be treated differently from boundary points. One way to illustrate this point is to simulate the wave equation (1) with 'absorbing' boundary conditions $u_t = \pm u_x$ at $x = 0, L$. This problem cannot be stated in the form (2) as the energy is no

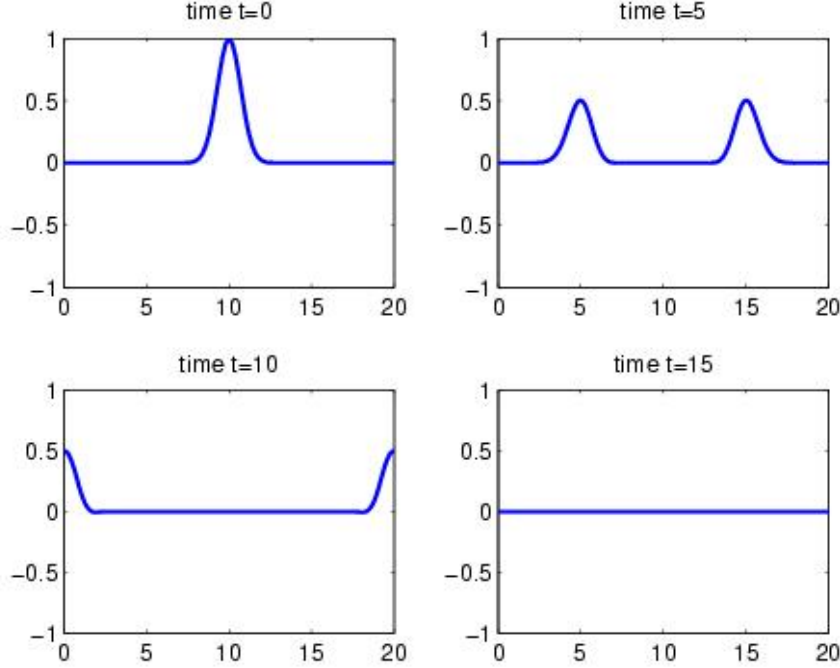

Figure 1: Time evolution of a initial pulse placed at $x = 10$ under the Preissman box scheme applied to the linear wave equation $u_{tt} = u_{xx}$ with absorbing boundary conditions $u_t = \pm u_x$ at $x = 0, L$.

longer a Hamiltonian function (the variational derivative of $H(\mathbf{u})$ no longer vanishes at the domain boundary). However, local conservation laws of symplecticity, energy and momentum still hold everywhere in the interior $x \in (0, L)$. This property is demonstrated for the Preissman box scheme discretization (see Section 6 and the Appendix for details) applied to (1) with $f = 0$. Due to the absorbing boundary conditions, an initial pulse placed at the center of the domain will eventually be radiated out of the domain. This qualitative solution behaviour is clearly captured by the Preissman box scheme as can be seen from Figures 1 & 2. Energy is exactly locally preserved for the simulation although the global energy is strictly decreasing once the wave reaches the boundary.

Multi-symplectic methods also allow for a combined treatment of spatial and temporal discretizations. For the above numerical example, this implies, for example, that the absorbing boundary conditions can be implemented such that no spurious numerical reflections are generated.¹

A potential difficulty with the multi-symplectic formulations is the enlarged phase space and the non-uniqueness of the formulations. Multi-symplectic formulations are also known only for a restricted class of Hamiltonian PDEs. While the frameworks for constructing multi-symplectic schemes are relatively new, some algorithms that can be shown to be multi-symplectic have been widely used in computational applications for a long time. Take for example the well-known and widely used leap-frog scheme [111]

$$u_i^{n+1} - 2u_i^n + u_i^{n-1} = \frac{\Delta t^2}{\Delta x^2} (u_{i+1}^n - 2u_i^n + u_{i-1}^n) - \Delta t^2 f(u_i^n),$$

which provides a multi-symplectic method for the wave equation (1) [23]. The leap-frog scheme is also at the heart of widely used schemes such as the Yee scheme [150] in electromagnetism [150] and

¹This property is somewhat special for the 1D linear wave equation and the Preissman box scheme discretization. The situation becomes more complex in higher dimensions and in case of non-local absorbing boundary conditions.

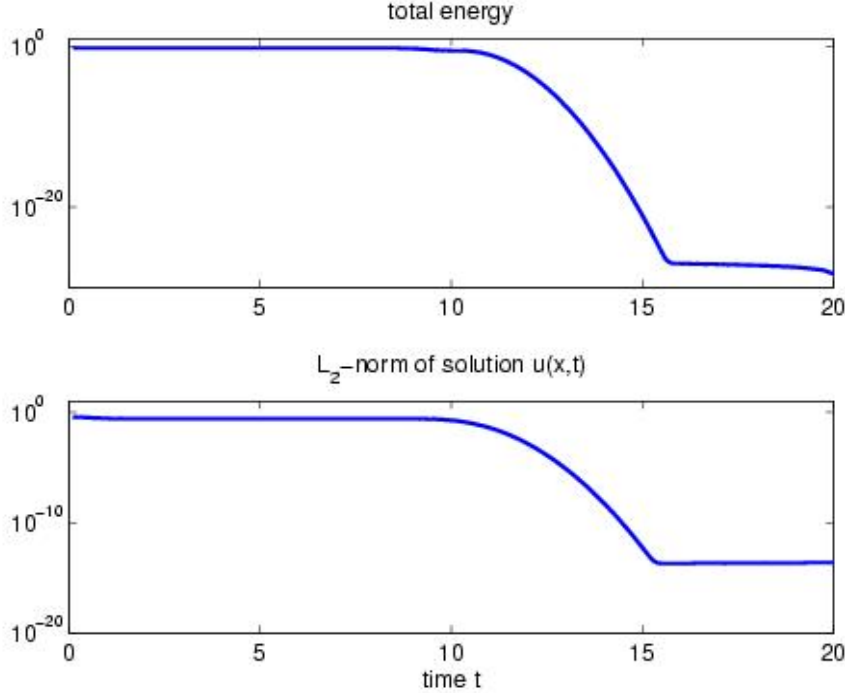

Figure 2: Time evolution of the total energy and the spatial l_2 -norm of the numerical solution u_i^n under the Preissman box scheme

the Hansen scheme [62] in fluid dynamics.

This survey aims to provide an introduction and overview of existing numerical methods and their conservation properties for Hamiltonian PDEs. Most of the discussion is restricted to systems with time and one space dimension as independent variables. The emphasis is on symplectic, multi-symplectic, and discrete variational methods.

Conservation properties are very important in the discretization of Hamiltonian PDEs, but the equations themselves are not in conservation form. The conservation laws are derived equations. The issues of discretization are therefore very different from the theory for hyperbolic conservation laws (see LEVEQUE [87] for example), where the equations themselves are in conservation law form.

2 From Hamiltonian ODEs to Hamiltonian PDEs

In this section, a brief overview of the concepts needed from Hamiltonian mechanics is given with emphasis on the aspects of ODEs that are needed in generalizing to PDEs. The textbooks by ARNOLD [4], OLVER [116], GOLDSTEIN [53], and MARSDEN & RATIU [100] provide excellent introductions to this subject area.

2.1 Finite-Dimensional Hamiltonian Systems

Historically, the construction of a Hamiltonian system started with a Lagrangian functional

$$\mathcal{L}[\mathbf{q}] = \int_{t_0}^{t_1} dt L(\mathbf{q}(t), \dot{\mathbf{q}}(t)), \quad \text{with} \quad L(\mathbf{q}, \dot{\mathbf{q}}) = \frac{1}{2} \dot{\mathbf{q}}^T \mathbf{M} \dot{\mathbf{q}} - V(\mathbf{q})$$

in the case of a conservative mechanical system with potential energy $V(\mathbf{q})$, positions $\mathbf{q} \in \mathbb{R}^n$ and (diagonal) mass matrix \mathbf{M} . Taking the functional derivative

$$\begin{aligned} \int dt \frac{\delta \mathcal{L}}{\delta \mathbf{q}} \cdot \boldsymbol{\xi} &= \lim_{\varepsilon \rightarrow 0} \frac{\mathcal{L}[\mathbf{q} + \varepsilon \boldsymbol{\xi}] - \mathcal{L}[\mathbf{q}]}{\varepsilon} \\ &= \int_{t_0}^{t_1} dt \left[\dot{\mathbf{q}}^T \mathbf{M} \dot{\boldsymbol{\xi}} - \nabla_{\mathbf{q}} V(\mathbf{q}) \cdot \boldsymbol{\xi} \right] \\ &= - \int_{t_0}^{t_1} dt \left[(\mathbf{M} \ddot{\mathbf{q}} + \nabla_{\mathbf{q}} V(\mathbf{q})) \cdot \boldsymbol{\xi} \right] \end{aligned}$$

for variations $\boldsymbol{\xi} : [t_0, t_1] \rightarrow \mathbb{R}^n$ with vanishing boundary variation, i.e., $\boldsymbol{\xi}(t_0) = \boldsymbol{\xi}(t_1) = \mathbf{0}$, leads to the Euler-Lagrange equation

$$\mathbf{0} = \frac{\delta \mathcal{L}}{\delta \mathbf{q}} = \mathbf{M} \ddot{\mathbf{q}} + \nabla_{\mathbf{q}} V(\mathbf{q}).$$

The Hamiltonian form is obtained by introducing (via a Legendre transform) the canonical momentum

$$\mathbf{p} = \nabla_{\dot{\mathbf{q}}} L(\mathbf{q}, \dot{\mathbf{q}}) = \mathbf{M} \dot{\mathbf{q}}$$

and the Hamiltonian function

$$H(\mathbf{q}, \mathbf{p}) = \mathbf{p} \dot{\mathbf{q}} - L(\mathbf{q}, \dot{\mathbf{q}}) = \frac{1}{2} \mathbf{p}^T \mathbf{M}^{-1} \mathbf{p} + V(\mathbf{q}).$$

The Hamiltonian system is now

$$\dot{\mathbf{p}} = -\nabla_{\mathbf{q}} H(\mathbf{q}, \mathbf{p}) = -\nabla_{\mathbf{q}} V(\mathbf{q}), \quad \dot{\mathbf{q}} = \nabla_{\mathbf{p}} H(\mathbf{q}, \mathbf{p}) = \mathbf{M}^{-1} \mathbf{p}.$$

We further abstract this formulation by introducing the phase space variable $\mathbf{z} = (\mathbf{q}^T, \mathbf{p}^T)^T \in \mathbb{R}^{2n}$ and the skew-symmetric matrix

$$\mathbf{J} = \begin{bmatrix} \mathbf{0}_n & -\mathbf{I}_n \\ \mathbf{I}_n & \mathbf{0}_n \end{bmatrix}$$

and the abstract Hamiltonian differential equation

$$\mathbf{J} \dot{\mathbf{z}} = \nabla_{\mathbf{z}} H(\mathbf{z}). \tag{5}$$

It is immediately deduced that the Hamiltonian (energy) H is conserved along solutions $\mathbf{z}(t)$ since

$$\dot{H} = \nabla_{\mathbf{z}} H \cdot \dot{\mathbf{z}} = -\dot{\mathbf{z}}^T \mathbf{J} \dot{\mathbf{z}} = 0.$$

Denote the flow map generated by a Hamiltonian system (5) by $\Psi_{t,H} : \mathbb{R}^{2n} \rightarrow \mathbb{R}^{2n}$. The flow map preserves the symplectic two-form

$$\omega = \frac{1}{2} \mathbf{d}\mathbf{z} \wedge \mathbf{J} \mathbf{d}\mathbf{z} = \mathbf{d}\mathbf{p} \wedge \mathbf{d}\mathbf{q} = \sum_{i=1}^n dp_i \wedge dq_i,$$

since solutions $\mathbf{z}(t) = \Psi_{t,H}(\mathbf{z}_0)$ satisfy the linearized equation

$$\mathbf{J} \mathbf{d}\dot{\mathbf{z}}(t) = \mathbf{A}(t) \mathbf{d}\mathbf{z}(t), \quad \mathbf{A}(t) = H_{\mathbf{z}\mathbf{z}}(\mathbf{z}(t)),$$

and since

$$\mathbf{d}\mathbf{z} \wedge (\mathbf{A} \mathbf{d}\mathbf{z}) = (\mathbf{A}^T \mathbf{d}\mathbf{z}) \wedge \mathbf{d}\mathbf{z} = -\mathbf{d}\mathbf{z} \wedge (\mathbf{A}^T \mathbf{d}\mathbf{z})$$

implies $\mathbf{dz} \wedge (\mathbf{A}\mathbf{dz}) = 0$ for symmetric matrices \mathbf{A} .

Given a (constant) skew-symmetric matrix \mathbf{J} , Hamiltonian differential equations (5) form a Lie algebra with the associated group formed by the symplectic transformations [4]. In finite dimensions, a comparable situation arises from the Lie algebra of skew-symmetric matrices and the associated Lie group of rotation matrices. An important difference exists however between finite and infinite dimensional Lie algebras. In finite dimensions, the Lie algebra provides a parametrization of the associated group near the identity. This is no longer the case for Hamiltonian differential equations, i.e., not all near identity symplectic transformations Φ can be generated by a flow map $\Psi_{\tau, \tilde{H}}$ of an appropriate Hamiltonian \tilde{H} . However, provided the symplectic transformation Φ is analytic, one can find (at least locally) a Hamiltonian \tilde{H} such that

$$\|\Phi(\mathbf{z}) - \Psi_{\tau, \tilde{H}}(\mathbf{z})\| \leq c_1 e^{-c_2/\tau},$$

where τ is given by

$$\tau = \sup_{\mathbf{z} \in \mathcal{K} \subset \mathbb{C}^{2n}} \|\Phi(\mathbf{z}) - \mathbf{z}\|,$$

c_1, c_2 are constants independent of Φ , and $\mathcal{K} \subset \mathbb{C}^{2n}$ is an appropriate subset. See the papers by NEISHTADT [113], BENETTIN & GIORGILLI [8], HAIRER & LUBICH [59], and REICH [118] for details.

This result has important ramifications for numerical methods. Given a discrete temporal lattice $t_n = n \Delta t$ and a numerical one-step method

$$\mathbf{z}^{n+1} = \Phi_{\Delta t}(\mathbf{z}^n)$$

of order $p \geq 1$, we obtain nearly exact conservation of a modified Hamiltonian \tilde{H} provided the map $\Phi_{\Delta t}$ is symplectic and the step-size Δt is sufficiently small. The modified Hamiltonian \tilde{H} may be chosen such that

$$|\tilde{H}(\mathbf{z}^n) - H(\mathbf{z}^n)| = \mathcal{O}(\Delta t^p).$$

A classical example is provided by the second-order Störmer-Verlet method

$$\mathbf{p}^{n+1/2} = \mathbf{p}^n - \frac{\Delta t}{2} \nabla_{\mathbf{q}} V(\mathbf{q}^n), \quad \mathbf{q}^{n+1} = \mathbf{q}^n + \Delta t \mathbf{M}^{-1} \mathbf{p}^{n+1/2}, \quad \mathbf{p}^{n+1} = \mathbf{p}^{n+1/2} - \frac{\Delta t}{2} \nabla_{\mathbf{q}} V(\mathbf{q}^{n+1}).$$

The textbooks by SANZ-SERNA & CALVO [125], HAIRER, LUBICH & WANNER [61], and LEIMKÜHLER & REICH [85] provide an introduction to symplectic integration methods and modified equation analysis. One can also start with the Lagrangian formulation and derive algorithms based on a discrete variational principle leading to variational integrators and this approach is reviewed in MARSDEN & WEST [102].

Two further concepts from Hamiltonian mechanics which will be needed for the PDE case are Hamilton's principle and Poisson brackets. It is easily verified that Hamilton's equations may be derived from the Lagrangian functional

$$\mathcal{L}[\mathbf{z}] = \int dt \left[\frac{1}{2} \mathbf{z}(t)^T \mathbf{J} \dot{\mathbf{z}}(t) - H(\mathbf{z}(t)) \right]$$

by varying both the \mathbf{q} 's and \mathbf{p} 's, i.e., $\delta \mathcal{L} / \delta \mathbf{z} = \mathbf{0}$. Such a formulation is useful for discussing symmetries and their associated invariants (Noether's theorem).

When \mathbf{J} is invertible, one can introduce the Poisson bracket

$$\{F, G\} = (\nabla_{\mathbf{z}} F)^T \mathbf{J}^{-1} \nabla_{\mathbf{z}} G$$

for any two functions $F, G : \mathbb{R}^{2n} \rightarrow \mathbb{R}$. Poisson brackets $\{\cdot, \cdot\}$ can be introduced in a more general setting under the conditions that (i) $\{F, G\} = -\{G, F\}$ (skew-symmetry) and (ii) $\{F, \{G, H\}\} +$

$\{G, \{H, F\}\} + \{H, \{F, G\}\} = 0$ (Jacobi identity) [116]. Given a Hamiltonian H , the time evolution of a function F is now determined by

$$\dot{F} = \{F, H\}$$

and we conclude, in particular, $\dot{H} = \{H, H\} = 0$ (conservation of energy) and $\dot{z}_i = \{z_i, H\}$, $i = 1, \dots, 2n$ (Hamiltonian equations of motion). Functions $C : \mathbb{R}^{2n} \rightarrow \mathbb{R}$, which are preserved for arbitrary Hamiltonians H , i.e., $\dot{C} = \{C, H\} = 0$, are called Casimir functions. Poisson bracket formulations are relevant, among other reasons, for rigid body dynamics. The Poisson bracket formulation is also used in the derivation of symplectic time-stepping methods, which are based on a splitting of the Hamiltonian H into integrable problems H_k such that $H = \sum_k H_k$ and composition of the associated flow maps $\Psi_{\Delta t, H_k}$. For a survey on splitting methods, see MCLACHLAN & QUISPTEL [105].

2.2 Infinite-Dimensional Hamiltonian Systems

An introduction to infinite-dimensional Hamiltonian system can be found in the textbooks by OLVER [116], MARSDEN & RATIU [100], and SALMON [123] as well as in the survey articles by MORRISON [110] and SHEPHERD [129].

Let us develop the basic ideas by describing the formal limiting process to an infinite-dimensional system for the semi-linear wave equation (1). Consider a spatial discretization

$$\ddot{u}_i = \frac{u_{i+1} - 2u_i + u_{i-1}}{\Delta x^2} - f(u_i), \quad i = 1, \dots, I, \quad (6)$$

with zero Dirichlet boundary conditions $u_0 = u_{I+1} = 0$. The equations (6) are a finite-dimensional Hamiltonian system with ‘coordinates’ $q_i = u_i$, ‘momenta’ $p_i = \dot{u}_i$, $i = 1, \dots, I$, Hamiltonian

$$H_{\Delta x}(\mathbf{q}, \mathbf{p}) = \sum_{i=1}^I \Delta x \left[\frac{1}{2} p_i^2 + \frac{(u_i - u_{i-1})^2}{4\Delta x^2} + \frac{(u_{i+1} - u_i)^2}{4\Delta x^2} + F(u_i) \right]$$

with $F'(u) = f(u)$, $\mathbf{q} = (q_1, \dots, q_I)^T$, $\mathbf{p} = (p_1, \dots, p_I)^T$, and Poisson bracket

$$\begin{aligned} \{F_{\Delta x}, G_{\Delta x}\}_{\Delta x} &= \Delta x^{-1} \sum_i [\nabla_{q_i} F_{\Delta x} \nabla_{p_i} G_{\Delta x} - \nabla_{p_i} F_{\Delta x} \nabla_{q_i} G_{\Delta x}] \\ &= \Delta x \left[\left(\frac{1}{\Delta x} \nabla_{\mathbf{q}} F_{\Delta x} \right) \cdot \left(\frac{1}{\Delta x} \nabla_{\mathbf{p}} G_{\Delta x} \right) - \left(\frac{1}{\Delta x} \nabla_{\mathbf{p}} F_{\Delta x} \right) \cdot \left(\frac{1}{\Delta x} \nabla_{\mathbf{q}} G_{\Delta x} \right) \right]. \end{aligned}$$

The following notation has been used $\nabla_{\mathbf{u}} G_{\Delta x} = (\partial_{u_0} G_{\Delta x}, \dots, \partial_{u_{N-1}} G_{\Delta x})^T$. In the limit $\Delta x \rightarrow 0$ and $I\Delta x = L$, we formally obtain $q(x) = u(x)$, $p(x) = \dot{u}(x)$, $x \in [0, L]$ with Dirichlet boundary conditions $u(0) = u(L) = 0$. We also have

$$\mathcal{H}[q, p] = \lim_{\Delta x \rightarrow 0} H_{\Delta x} = \int_0^L dx \left[\frac{1}{2} p^2 + \frac{1}{2} q_x^2 + F(q) \right].$$

and Poisson bracket

$$\{\mathcal{F}, \mathcal{G}\} = \lim_{\Delta x \rightarrow 0} \{F_{\Delta x}, G_{\Delta x}\}_{\Delta x} = \int dx \left[\frac{\delta \mathcal{F}}{\delta q} \frac{\delta \mathcal{G}}{\delta p} - \frac{\delta \mathcal{F}}{\delta p} \frac{\delta \mathcal{G}}{\delta q} \right].$$

Indeed, the functional derivative $\delta \mathcal{F} / \delta q$ is, for example, defined by

$$\int dx \frac{\delta \mathcal{F}}{\delta q} \cdot v = \lim_{\varepsilon \rightarrow 0} \frac{\mathcal{F}[q + \varepsilon v, p] - \mathcal{F}[q, p]}{\varepsilon} \approx \sum_i \frac{\partial}{\partial q_i} F_{\Delta x}(\mathbf{q}, \mathbf{p}) v_i$$

and we obtain

$$\Delta x \frac{\delta \mathcal{F}}{\delta q}(x_i) \approx \frac{\partial}{\partial q_i} F_{\Delta x}(\mathbf{q}, \mathbf{p}).$$

It follows that the wave equation (1) can be written in the ‘classical mechanics’ form

$$\dot{p} = -\frac{\delta \mathcal{H}}{\delta q}, \quad \dot{q} = +\frac{\delta \mathcal{H}}{\delta p}.$$

We may also introduce the symplectic form

$$\omega = \sum_i \Delta x dp_i \wedge dq_i$$

for the spatially discretized semi-linear wave equation, which, in the limit $\Delta x \rightarrow 0$, becomes

$$\Omega = \int dx dp \wedge dq$$

and is preserved under the time evolution of the semi-linear wave equations.

More generally, infinite-dimensional Hamiltonian systems are defined by (i) a phase (function) space $z \in Z$, (ii) a Hamiltonian functional $\mathcal{H} : Z \rightarrow \mathbb{R}$, and (iii) a Poisson bracket $\{\mathcal{F}, \mathcal{G}\}$, which has to satisfy the skew-symmetry condition $\{\mathcal{F}, \mathcal{G}\} = -\{\mathcal{G}, \mathcal{F}\}$ and the Jacobi identity $\{\mathcal{F}, \{\mathcal{G}, \mathcal{H}\}\} + \{\mathcal{G}, \{\mathcal{H}, \mathcal{F}\}\} + \{\mathcal{H}, \{\mathcal{F}, \mathcal{G}\}\} = 0$.

There are other, largely equivalent, ways to introduce infinite-dimensional Hamiltonian systems. As an example, we mention that the semi-linear wave equation (1) may be derived from the Lagrangian functional

$$\mathcal{L} = \int dt \int dx \left[\frac{1}{2} u_t^2 - \frac{1}{2} u_x^2 - F(u) \right] \quad (7)$$

and the standard variational derivative of \mathcal{L} .

One of the most well-known Hamiltonian PDEs is the KdV equation

$$u_t = -uu_x - u_{xxx} = -\partial_x \left(\frac{1}{2} u^2 + u_{xx} \right) \quad (8)$$

which is a non-trivial application of the Hamiltonian framework. The KdV equation conserves the energy

$$\mathcal{H}[u] = \int dx \left[\frac{1}{6} u^3 - \frac{1}{2} u_x^2 \right],$$

since

$$\dot{\mathcal{H}} = \int dx \left[\frac{1}{2} u^2 u_t - u_x u_{xt} \right] = \int dx \left[\left(\frac{1}{2} u^2 + u_{xx} \right) u_t \right] = \int dx \left[\left(\frac{1}{2} u^2 + u_{xx} \right) \partial_x \left(\frac{1}{2} u^2 + u_{xx} \right) \right] = 0$$

under appropriate boundary conditions. It can also be verified that

$$\mathcal{C}[u] = \int dx u$$

is a conserved quantity, i.e., $\dot{\mathcal{C}} = 0$. To derive a Hamiltonian formulation, we note that the KdV equation may be written in the form

$$u_t = -\partial_x \left[\frac{1}{2} u^2 + u_{xx} \right] = -\partial_x \frac{\delta \mathcal{H}}{\delta u}.$$

This formulation suggests the Poisson bracket

$$\{\mathcal{F}, \mathcal{G}\} = - \int dx \frac{\delta \mathcal{F}}{\delta u} \frac{\partial}{\partial x} \frac{\delta \mathcal{G}}{\delta u},$$

which indeed satisfies the required condition of skew-symmetry and Jacobi's identity. It turns out that $\{\mathcal{C}, \mathcal{F}\} = 0$ for any choice of \mathcal{F} and, hence, \mathcal{C} is a Casimir function of the KdV Poisson bracket.

Our third example of a Hamiltonian PDE comes from geophysical fluid dynamics. See the textbooks by SALMON [123] and DURRAN [39] for an introduction to mathematical aspects of geophysical fluid dynamics and numerical techniques. The equations of motion for a shallow homogeneous fluid, in a coordinate system rotating at constant angular velocity $f/2$ about the vertical, are

$$\mathbf{v}_t + (\mathbf{v} \cdot \nabla_{\mathbf{x}}) \mathbf{v} + f \mathbf{k} \times \mathbf{v} = -g \nabla_{\mathbf{x}} h, \quad (9)$$

$$h_t + \nabla_{\mathbf{x}} \cdot (h \mathbf{v}) = 0, \quad (10)$$

where $\mathbf{v} \in \mathbb{R}^2$ is the horizontal velocity field, h is the fluid depth, g is the gravitational acceleration, and \mathbf{k} is the unit vertical vector. The shallow-water equations (9)-(10) preserve the Hamiltonian (energy) functional

$$\mathcal{H}[h, \mathbf{v}] = \frac{1}{2} \iint dx (h \|\mathbf{v}\|^2 + gh^2).$$

The fluid motion describes a transformation from initial particle positions, which we denote by $\mathbf{a} = (a, b)^T \in \mathbb{R}^2$ to their positions $\bar{\mathbf{x}}(t, \mathbf{a}) = (\bar{x}(t, a, b), \bar{y}(t, a, b))^T \in \mathbb{R}^2$ at time $t > t_0$. This transformation allows us to express the continuity equation (10) in the equivalent integral form

$$h(\mathbf{x}, t) = \iint dadb h_0(\mathbf{a}) \delta(\mathbf{x} - \bar{\mathbf{x}}(t, \mathbf{a})), \quad (11)$$

where $h_0(\mathbf{a}) = h(\mathbf{a}, t_0)$ is the density at the initial time, $\delta(\cdot)$ denotes the Dirac delta function, and $\mathbf{x} = (x, y)^T \in \mathbb{R}^2$ are fixed Eulerian positions. We now take labels $\mathbf{a} \in \mathbb{R}^2$ and time $t \in \mathbf{R}^+$ as independent variables and postulate the Lagrangian functional

$$\mathcal{L} = \mathcal{T} - \mathcal{V} = \frac{1}{2} \int dt \iint dadb h_0 (\bar{\mathbf{x}}_t + f \mathbf{k} \times \bar{\mathbf{x}}) \cdot \bar{\mathbf{x}}_t - \frac{1}{2} \int dt \iint dxdy gh^2. \quad (12)$$

Note that we have to distinguish between a partial time derivative for fixed labels $\mathbf{a} \in \mathbb{R}^2$ and a partial time derivative for fixed Eulerian positions $\mathbf{x} \in \mathbb{R}^2$. For a function f , the relation between these two partial derivatives is given by

$$\frac{\partial f}{\partial t} \Big|_{\mathbf{a}=\text{const.}} = \frac{\partial f}{\partial t} \Big|_{\mathbf{x}=\text{const.}} + \mathbf{v} \cdot \nabla_{\mathbf{x}} f.$$

To find the variational derivative and the associated Euler-Lagrange equations, we need to first derive the variational derivative of \mathcal{V} , i.e.

$$\begin{aligned} \int dt \iint dadb \left[\frac{\partial \mathcal{V}}{\partial \bar{\mathbf{x}}} \cdot \mathbf{w} \right] &= \lim_{\varepsilon \rightarrow 0} \frac{\mathcal{V}(\bar{\mathbf{x}} + \varepsilon \mathbf{w}) - \mathcal{V}(\bar{\mathbf{x}})}{\varepsilon} \\ &= \int dt \iint dxdy gh ((-\nabla_{\mathbf{x}} h) \cdot \mathbf{w}), \end{aligned}$$

where we made use of (11). By the divergence theorem and under appropriate boundary conditions, we then obtain

$$-g \iint dxdy h (\nabla_{\mathbf{x}} h \cdot \mathbf{w}) = g \iint dxdy (h \nabla_{\mathbf{x}} h) \cdot \mathbf{w}.$$

Making use of the equivalent differential representation

$$h \frac{\partial(x, y)}{\partial(a, b)} = h_0$$

for (11), we transform integrals over Eulerian positions $\mathbf{x} \in \mathbb{R}^2$ to integrals over label space $\mathbf{a} \in \mathbb{R}^2$, i.e.

$$\iint dx dy [gh \nabla_{\mathbf{x}} h] \cdot \mathbf{w} = \iint da db [gh_0 \nabla_{\mathbf{x}} h] \cdot \mathbf{w}$$

and, finally, obtain

$$\frac{\delta \mathcal{V}}{\delta \bar{\mathbf{x}}} = gh_0 \nabla_{\mathbf{x}} h.$$

Using this result and the functional derivative for \mathcal{T} , we obtain the Euler-Lagrange equations

$$\frac{\partial^2 \bar{\mathbf{x}}}{\partial t^2} + f \mathbf{k} \times \frac{\partial \bar{\mathbf{x}}}{\partial t} + g \nabla_{\mathbf{x}} h = 0, \quad (13)$$

where the last term is the gradient of (11) with respect to its first argument, evaluated at $\bar{\mathbf{x}}$. The equations (13) are the shallow-water momentum equations from a Lagrangian fluid dynamics perspective. Using $\mathbf{v} = \bar{\mathbf{x}}_t$ and

$$\frac{\partial \mathbf{v}}{\partial t} \Big|_{\mathbf{a}=\text{const.}} = \frac{\partial \mathbf{v}}{\partial t} \Big|_{\mathbf{x}=\text{const.}} + (\mathbf{v} \cdot \nabla_{\mathbf{x}}) \mathbf{v},$$

the equivalence to the Eulerian form (9) is immediate.

2.3 Multi-Symplectic Hamiltonian PDEs

Classical Hamiltonian formulations for PDEs take time as a preferred direction with space treated passively. In many applications it is advantageous to put space and time on an equal footing. This leads to the idea of multi-symplectic Hamiltonian PDEs.

The simplest way to view a multi-symplectic formulation is to start with a Lagrangian and take a covariant Legendre transform. In a covariant Legendre transform – also called total Legendre transform – one eliminates all first-order partial derivatives and transforms to “poly-momenta” or “multi-momenta”. For example, starting with the Lagrangian for the semi-linear wave equation (7), a covariant Legendre transform leads to momenta

$$v := \frac{\delta L}{\delta u_t} = u_t \quad \text{and} \quad w := \frac{\delta L}{\delta u_x} = -u_x,$$

a covariant Hamiltonian function

$$S = vu_t + wu_x - L = \frac{1}{2}v^2 - \frac{1}{2}w^2 + F(u).$$

and governing equations

$$\begin{bmatrix} 0 & -1 & 0 \\ 1 & 0 & 0 \\ 0 & 0 & 0 \end{bmatrix} \begin{pmatrix} u \\ v \\ w \end{pmatrix}_t + \begin{bmatrix} 0 & 0 & -1 \\ 0 & 0 & 0 \\ 1 & 0 & 0 \end{bmatrix} \begin{pmatrix} u \\ v \\ w \end{pmatrix}_x = \begin{pmatrix} f(u) \\ v \\ -w \end{pmatrix}. \quad (14)$$

Note that this multi-symplectic formulation differs from that introduced in (3). In fact the system (3) can also be deduced by a modification of the Legendre transform on differential forms [15].

This example and its comparison with (3) highlight a key issue with Hamiltonian PDEs. There are a number of ways to approach the construction of multi-symplectic PDEs, and the Legendre transform in the PDE setting is not always reliable: it is often singular, and is difficult to define for higher-order field theories [126]. See [7, 14, 15, 40, 25, 57, 82, 101, 114] for a range of approaches to multi-symplectic structures and multi-symplectic PDEs.

Fortunately in most cases the multi-symplectic Hamiltonian PDE in one space dimension and time can be reduced to the canonical form

$$\mathbf{K}\mathbf{z}_t + \mathbf{L}\mathbf{z}_x = \nabla_{\mathbf{z}}S(\mathbf{z}), \quad \mathbf{z} \in \mathbb{R}^d, \quad (15)$$

for some $d \geq 3$ where \mathbf{K} and \mathbf{L} are constant skew-symmetric matrices and S is a given smooth function of \mathbf{z} , and $\nabla_{\mathbf{z}}S$ is the classical gradient on \mathbb{R}^d . This formulation of multi-symplectic Hamiltonian PDEs has been widely used in wave propagation and pattern formation (cf. [14, 13, 16, 17, 18, 19, 24]).

One weakness of the formulation (15) is that it is not coordinate-free on the base manifold: (t, x) -space. This is quite satisfactory for many applications where one wants to maintain the distinction between space and time. On the other hand, it is possible to give a coordinate-free formulation of the left hand side of (15) for covariant PDEs using the theory of multi-symplectic Dirac operators on the total exterior algebra bundle of the base manifold (see §7 and [15]).

In this paper the abstract formulation (15) is taken as a starting point for development of numerical methods for multi-symplectic Hamiltonian PDEs. Equations of this form have the property that symplecticity is conserved

$$\omega_t + \kappa_x = 0 \quad \text{with} \quad \omega := \frac{1}{2}d\mathbf{z} \wedge \mathbf{K}d\mathbf{z}, \quad \kappa := \frac{1}{2}d\mathbf{z} \wedge \mathbf{L}d\mathbf{z}, \quad (16)$$

and when S does not depend explicitly on t and x energy and momentum are conserved

$$\begin{aligned} E_t + F_x &= 0, & E(\mathbf{z}) &= S(\mathbf{z}) - \frac{1}{2}\mathbf{z}^T \mathbf{L}\mathbf{z}_x, & F(\mathbf{z}) &= \frac{1}{2}\mathbf{z}^T \mathbf{L}\mathbf{z}_t, \\ I_t + G_x &= 0, & G(\mathbf{z}) &= S(\mathbf{z}) - \frac{1}{2}\mathbf{z}^T \mathbf{K}\mathbf{z}_t, & I(\mathbf{z}) &= \frac{1}{2}\mathbf{z}^T \mathbf{K}\mathbf{z}_x, \end{aligned} \quad (17)$$

When designing a geometric integrator for (15), the principal requirement will be that the discretization conserves symplecticity. It is not possible in general to exactly conserve energy and momentum as well in a uniform discretization, but how closely energy and momentum are conserved will be a property of interest. It should be kept in mind though that there are cases where exact conservation of a discrete form of (17) could be preferable. This point was stressed by SIMO and his co-workers in the context of elastodynamics (see, e.g., [130, 55]).

In the previous subsection it was shown that KdV has a classical Hamiltonian formulation. However it is not so easy to see that it is also multi-symplectic. Letting $u = \phi_x$, the canonical Lagrangian for the KdV equation is

$$\mathcal{L} = \int dt \int dx \left[\frac{1}{2}\phi_x \phi_t + \frac{1}{6}\phi_x^3 - \frac{1}{2}\phi_{xx}^2 \right]. \quad (18)$$

This Lagrangian is degenerate and involves second derivatives and therefore standard theory of Legendre transformation fails. However, as shown by BRIDGES & DERKS [16], there is a multi-symplectic formulation for KdV of the type (15) with $d = 4$, $\mathbf{z} = (\phi, u, v, w)$

$$\mathbf{K} = \begin{bmatrix} 0 & 1 & 0 & 0 \\ -1 & 0 & 0 & 0 \\ 0 & 0 & 0 & 0 \\ 0 & 0 & 0 & 0 \end{bmatrix}, \quad \mathbf{L} = \begin{bmatrix} 0 & 0 & 0 & 1 \\ 0 & 0 & -1 & 0 \\ 0 & 1 & 0 & 0 \\ -1 & 0 & 0 & 0 \end{bmatrix}.$$

and $S(\mathbf{z}) = \frac{1}{2}v^2 - uw + \frac{1}{6}u^3$.

Multi-symplectic formulations of the shallow water equations (9)-(10) and related equations in geophysical fluid dynamics are given in [21].

3 Semi-Discretization and the Method of Lines

A popular method for discretizing PDEs is to discretize in space and time independently. The PDE is first discretized in space resulting in a large system of ODEs. The resulting system of ODEs is then integrated by an appropriate time-stepping method. This methodology may also be applied to infinite-dimensional Hamiltonian systems [80, 90, 104]. However, particular care is required to ensure that the resulting finite-dimensional system is also Hamiltonian. There are two ways to achieve this in a systematic manner, by either starting from a Lagrangian functional or by starting with the Hamiltonian functional and the Poisson bracket.

The paper by MCLACHLAN [104] and the book by LEIMKUHNER & REICH [85] have a summary of discretization methods for Hamiltonian PDEs based on the method of lines. The book by MORTON & MAYERS [111] provides a general introduction to numerical methods for PDEs. The books by ABBOTT [1], ABBOTT & BASCO [2] and DURRAN [39] give a more detailed introduction to discretization of PDEs in the context of fluid dynamics.

In this survey, special emphasis is put on Hamiltonian discretization methods. Clearly, preservation of other conserved quantities can be important as well and such methods may lead to other types of spatial and temporal discretizations. We mention the work of JIMÉNEZ [77], LI & VU-QUOC [91, 141], STRAUSS & VÁZQUEZ [133], ARAKAWA [3], and SALMON [124] on conservative finite-difference methods. We would like to also mention recent work on mimetic finite difference methods by SHASHKOV and co-workers (see, e.g., [128, 73]) as well as on discrete differential forms and their numerical implementation by BOSSAVIT [12], HIPTMAIR [63], and DESBRUN ET AL [37]. The use of mimetic difference methods and discrete differential forms are useful when the multi-symplectic PDEs are formulated in terms of continuous differential forms (cf. Section 7).

3.1 Discrete Hamiltonian Approach

Let us assume that the infinite-dimensional system is characterized by a phase space Z , a Hamiltonian functional \mathcal{H} , and a Poisson bracket $\{\cdot, \cdot\}$. A discretization starts with a finite-dimensional approximation $Z_{\Delta x}$ to Z . Further, upon replacing exact integrals by some quadrature formulas, we obtain a finite-dimensional energy approximation $H_{\Delta x}(\mathbf{z})$ and a bracket $\{\cdot, \cdot\}_{\Delta x}$. The finite-dimensional equations of motion are then

$$\dot{\mathbf{z}} = \{\mathbf{z}, H_{\Delta x}\}_{\Delta x}, \quad \mathbf{z} \in Z_{\Delta x}.$$

These equations are Hamiltonian if the ‘numerical’ bracket $\{\cdot, \cdot\}_{\Delta x}$ can be shown to be anti-symmetric and to satisfy the Jacobi identity. While anti-symmetry is relatively easy to achieve, it can be impossible in some cases to ensure

$$\{F_{\Delta x}, \{G_{\Delta x}, H_{\Delta x}\}_{\Delta x}\}_{\Delta x} + \{G_{\Delta x}, \{H_{\Delta x}, F_{\Delta x}\}_{\Delta x}\}_{\Delta x} + \{H_{\Delta x}, \{F_{\Delta x}, G_{\Delta x}\}_{\Delta x}\}_{\Delta x} = 0.$$

This is the case, for example, for the shallow-water equations (9)-(10) and their non-canonical Poisson bracket formulation. (See [129] for a discussion of non-canonical Eulerian descriptions of the shallow-water equations.) In other cases the above approach can be carried out quite easily as we have already demonstrated in the previous section for the semi-linear wave equation (1). A rigorous convergence analysis of the finite-dimensional Hamiltonian approximation to the PDE limit is, in general, non-trivial. However, a second order local truncation error can easily be achieved by using symmetric finite difference approximations in $H_{\Delta t}$ and $\{\cdot, \cdot\}_{\Delta x}$.

The KdV equation (8) also possesses a non-canonical Poisson bracket but a finite-dimensional Poisson bracket is easily found. Assume, for simplicity, that the domain $x \in [0, L]$ is equipped with periodic boundary conditions. We introduce grid points $x_i = i\Delta x$, $i = 0, \dots, N-1$, $\Delta x = L/N$ and

solution approximations $u_i \approx u(x_i)$. A simple approximation to the Hamiltonian is provided by

$$H_{\Delta t}(\mathbf{u}) = \Delta x \sum_{i=0}^{N-1} \left[\frac{1}{6} u_i^3 - \left(\frac{u_{i+1} - u_i}{\Delta x} \right)^2 \right]$$

where we set $u_N = u_0$ and $\mathbf{u} = (u_0, \dots, u_{N-1})^T$. Somewhat more care is required to discretize the Poisson bracket. A possible choice is

$$\begin{aligned} \{F_{\Delta x}, G_{\Delta x}\}_{\Delta x} &= -\Delta x^{-1} \sum_{i=0}^{N-1} \left[\partial_{u_i} F_{\Delta x} \frac{\partial_{u_{i+1}} G_{\Delta x} - \partial_{u_{i-1}} G_{\Delta x}}{2\Delta x} \right] \\ &= \Delta x^{-1} \sum_{i=0}^{N-1} \left[\frac{\partial_{u_{i+1}} F_{\Delta x} - \partial_{u_{i-1}} F_{\Delta x}}{2\Delta x} \partial_{u_i} G_{\Delta x} \right] \end{aligned}$$

where we set $u_{-1} = u_{N-1}$. It is easy to verify that $\{F, G\}_{\Delta x} = -\{G, F\}_{\Delta x}$. The Jacobi identity is trivially satisfied as

$$\{F_{\Delta x}, G_{\Delta x}\}_{\Delta x} = \nabla_{\mathbf{u}} F_{\Delta x}^T \mathbf{B} \nabla_{\mathbf{u}} G_{\Delta x}$$

for a constant (skew-symmetric) structure matrix $\mathbf{B} \in \mathbb{R}^{N \times N}$. The spatially discrete KdV equations are now given by

$$\begin{aligned} \dot{u}_i &= \{u_i, H_{\Delta x}\}_{\Delta x} = -\Delta x^{-1} \frac{\partial_{u_{i+1}} H_{\Delta x} - \partial_{u_{i-1}} H_{\Delta x}}{2\Delta x} \\ &= -\frac{u_{i+1}^2 - u_{i-1}^2}{\Delta x} - \frac{u_{i+2} - 2u_{i+1} + 2u_{i-1} - u_{i-2}}{2\Delta x^3}. \end{aligned}$$

Clearly these finite-dimensional equations are not unique. Other choices for the spatial discretization of the Hamiltonian and the Poisson bracket would lead to other finite-dimensional approximations.

A particularly difficult problem to discretize is the Euler equations of fluid dynamics – in the Eulerian representation. The Poisson bracket is non-canonical, and standard discretizations result in a finite-dimensional Poisson bracket which fails to satisfy the Jacobi condition. Indeed, the only known successful discretization which results in a proper finite-dimensional Poisson system is one proposed by ZEITLIN [151], which has been numerically implemented by MCLACHLAN [103]. However, this discretization only works for incompressible fluids in two space dimensions subject to periodic boundary conditions, and no extension to other ideal fluid equations is known.

We have only given examples for which the spatial mesh is homogeneous. Finite dimensional Hamiltonian approximation can also be derived for non-constant mesh-sizes. However, those discretization can lead to spurious wave reflections across changes in the mesh-size. A detailed discussion of this phenomena is given by FRANK & REICH [50] (see also VICHNEVETSKY & BOWLES [140] and TREFETHEN [139]).

3.2 Discrete Lagrangian Approach

When the PDE is the Euler-Lagrange equation associated with some Lagrangian \mathcal{L} , then another approach to the method of lines is to discretize the Lagrangian functional directly. As an example, consider the Lagrangian formulation (13) of the rotating shallow water equations. Introduce an Eulerian grid $\mathbf{x}_{ij} = (i\Delta x, j\Delta y)^T$ and another grid in label space, i.e., $\mathbf{a}_{kl} = (k\Delta a, l\Delta b)^T$. For simplicity, assume that $\Delta x = \Delta y$ and $\Delta a = \Delta b$. First formulate a discrete conservation law of mass based on a regularized form of (11):

$$h_{\Delta x}(\mathbf{x}_{ij}, t) = \iint dadb h_0(\mathbf{a}) \psi_{\Delta x}(\mathbf{x}_{ij} - \bar{\mathbf{x}}(\mathbf{a}, t))$$

where $\psi_{\Delta x}$ is a positive function with $\psi_{\Delta x}(\mathbf{x}) = \psi_{\Delta x}(-\mathbf{x})$, $\iint dx dy \psi_{\Delta x}(\mathbf{x}) = 1$, and $\lim_{\Delta x \rightarrow 0} \psi_{\Delta x} = \delta$. We may now approximate the integral by

$$h_{\Delta x, \Delta a}(\mathbf{x}_{ij}, t) = \sum_{k,l} \Delta a^2 h_0(\mathbf{a}_{kl}) \psi_{\Delta x}(\mathbf{x}_{ij} - \bar{\mathbf{x}}(\mathbf{a}_{kl}, t)).$$

This equation can be simplified by introducing particles with location

$$\bar{\mathbf{x}}_{kl}(t) = \bar{\mathbf{x}}(\mathbf{a}_{kl}, t)$$

and mass

$$m_{kl} = \Delta a^2 h_0(\mathbf{a}_{kl}),$$

i.e.,

$$h_{\Delta x, \Delta a}(\mathbf{x}_{ij}, t) = \sum_{k,l} m_{kl} \psi_{\Delta x}(\mathbf{x}_{ij} - \bar{\mathbf{x}}_{kl}(t)).$$

This formulation is further shortened to

$$h_{ij}(t) = \sum_{k,l} m_{kl} \psi_{ij}(\bar{\mathbf{x}}_{kl}(t)),$$

where $\psi_{ij}(\cdot) = \psi_{\Delta x}(\cdot - \mathbf{x}_{ij})$ and $h_{ij}(t) = h_{\Delta x, \Delta a}(\mathbf{x}_{ij}, t)$.

Now use these formulas to spatially discretize the Lagrangian functional (12),

$$\mathcal{L}_{\Delta x, \Delta a} = \int dt \sum_{kl} m_{kl} \left(\frac{d}{dt} \bar{\mathbf{x}}_{kl} + f \mathbf{k} \times \bar{\mathbf{x}}_{kl} \right) \cdot \frac{d}{dt} \bar{\mathbf{x}}_{kl} - \frac{1}{2} \int dt \sum_{ij} \Delta x^2 g h_{ij}^2.$$

The associated (finite-dimensional) Euler-Lagrange equations are

$$\frac{d^2 \bar{\mathbf{x}}_{kl}}{dt^2} + f \mathbf{k} \times \frac{d \bar{\mathbf{x}}_{kl}}{dt} + g \sum_{ij} \Delta x^2 \nabla_{\bar{\mathbf{x}}_{kl}} \psi_{ij}(\bar{\mathbf{x}}_{kl}) h_{ij} = 0.$$

From a numerical point of view it is desirable that the basis functions ψ_{ij} form a partition of unity, i.e.,

$$\sum_{ij} \psi_{ij}(\mathbf{x}) = C = \text{const.}$$

since this implies

$$\sum_{ij} \nabla_{\bar{\mathbf{x}}_{kl}} \psi_{ij}(\bar{\mathbf{x}}_{kl}) h_{ij} = 0$$

for $h_{ij} = \text{const.}$ This property is satisfied by tensor product B-splines over a regular grid \mathbf{x}_{ij} , i.e.

$$\psi_{ij}(\mathbf{x}) = \Delta x^{-2} \phi_i(x/\Delta x) \phi_j(y/\Delta x)$$

with B-spline ϕ_i . Since $\sum_i \phi_i(x) = 1$, we obtain $C = 1/\Delta x^2$ and

$$\begin{aligned} \sum_{ij} \Delta x^2 h_{ij} &= \sum_{ij} \Delta x^2 \sum_{kl} m_{kl} \psi_{ij}(\bar{\mathbf{x}}_{kl}) \\ &= C \Delta x^2 \sum_{kl} \Delta a^2 h_0(\mathbf{a}_{kl}) \\ &= \sum_{kl} \Delta a^2 h_0(\mathbf{a}_{kl}), \end{aligned}$$

which encodes conservation of mass over the Eulerian grid. See the papers by FRANK, GOTTWALD & REICH [45], FRANK & REICH [48, 49], DIXON & REICH [38] and COTTER & REICH [35] for more details.

Particle methods for fluid dynamics were first proposed by LUCY [93] and GINGOLD & MONAGHAN [52] under the name smoothed particle hydrodynamics (SPH). The SPH method was independently suggested by SALMON [122] in the context of geophysical fluid dynamics. The particle-mesh method, described in the textbooks by HOCKNEY & EASTWOOD [64] and BIRDSALL & LANGDON [11], provide an alternative approach to discrete Lagrangian fluid dynamics.

4 Implicit Time-Stepping and Regularized PDEs

Once a finite-dimensional Hamiltonian system has been derived by any of the methods described in the previous sections, a symplectic method can be applied in time to complete the discretization in space and time. This basic approach has been discussed, for example, by MCLACHLAN [104]. An interesting, non-trivial application has been provided by FRANK, HUANG & LEIMKUEHLER [46, 43] for classical spin systems.

In this section, time-stepping methods are discussed from a slightly different point of view. Namely, we take the infinite-dimensional description as our starting point and apply a time-stepping method directly to these equations. This approach to the discretization of PDEs is sometimes referred to as Rothe’s method. Rothe’s approach allows one to study the stability (and convergence) of time-stepping algorithms for PDEs without having to take a Δx dependence into account. In other words, we will look at implicit time-stepping methods which do not suffer from a CFL stability condition [111]. The basics of this approach are discussed in the following subsection. See, e.g., [127] to get a flavour of the theoretical implications.

4.1 Rothe’s Method and the Implicit Midpoint Time Discretization

Represent the class of evolutionary equations by

$$\mathbf{z}_t = \{\mathbf{z}, \mathcal{H}\} = \mathcal{X}(\mathbf{z}).$$

Assume that there is only a single spatial dimension, denoted by $x \in [0, L] \subset \mathbb{R}$. Furthermore, appropriate energy conserving boundary conditions (such as periodic boundary conditions) are assumed.

Two popular methods for discretizing Hamiltonian PDEs in time are the implicit midpoint method

$$\frac{\mathbf{z}^{n+1} - \mathbf{z}^n}{\Delta t} = \mathcal{X}(\mathbf{z}^{n+1/2}), \quad \mathbf{z}^{n+1/2} = \frac{1}{2} (\mathbf{z}^{n+1} + \mathbf{z}^n),$$

and the trapezoidal rule

$$\frac{\mathbf{z}^{n+1} - \mathbf{z}^n}{\Delta t} = \frac{\mathcal{X}(\mathbf{z}^{n+1}) + \mathcal{X}(\mathbf{z}^n)}{2}.$$

The implicit midpoint method preserves a symplectic form Ω (possibly non-canonical) provided the associated Poisson bracket is of the general form

$$\{\mathcal{F}, \mathcal{G}\} = \int dx \left\{ \frac{\delta \mathcal{F}}{\delta \mathbf{z}} \cdot \mathcal{J} \frac{\delta \mathcal{G}}{\delta \mathbf{z}} \right\},$$

where \mathcal{J} is a (invertible) constant skew-symmetric operator, i.e.

$$\int dx \mathbf{u} \cdot (\mathcal{J} \mathbf{v}) = - \int dx (\mathcal{J} \mathbf{u}) \cdot \mathbf{v}$$

for any two functions $\mathbf{u}, \mathbf{v} : [0, L] \rightarrow \mathbb{R}^k$. In case of the semi-linear wave equation $k = 2$ and

$$\mathcal{J} = \begin{bmatrix} 0 & +1 \\ -1 & 0 \end{bmatrix}.$$

The trapezoidal rule is not a symplectic method in the above sense but, since it is conjugate to the implicit midpoint method by a transformation of variables, the numerical behavior of both methods is comparable. (See, for example, the paper by HAIRER & LUBICH [60].) The trapezoidal rule extends to second-order evolutionary equations of the form

$$\mathbf{z}_{tt} = \mathcal{F}(\mathbf{z}).$$

Elementary manipulations yield the formulation

$$\mathbf{z}^{n+1} - 2\mathbf{z}^n + \mathbf{z}^{n-1} = \Delta t^2 \mathcal{F}(\mathbf{z}^n) + \frac{\Delta t^2}{4} [\mathcal{F}(\mathbf{z}^{n+1}) - 2\mathcal{F}(\mathbf{z}^n) + \mathcal{F}(\mathbf{z}^{n-1})].$$

Both the implicit midpoint and the trapezoidal methods lead to fully implicit time-stepping methods. In many cases one can, however, split off a linear part and write the evolutionary system in the form

$$\mathbf{z}_{tt} = \mathcal{F}(\mathbf{z}) = \mathcal{A}\mathbf{z} + \mathcal{R}(\mathbf{z}).$$

Linearly (stable) implicit discretizations are provided by the family of methods

$$\mathbf{z}^{n+1} - 2\mathbf{z}^n + \mathbf{z}^{n-1} = \Delta t^2 \mathcal{F}(\mathbf{z}^n) + \alpha^2 \Delta t^2 \mathcal{A} [\mathbf{z}^{n+1} - 2\mathbf{z}^n + \mathbf{z}^{n-1}]$$

for $\alpha \geq 1/2$. This is formally equivalent to

$$\mathbf{z}^{n+1} - 2\mathbf{z}^n + \mathbf{z}^{n-1} = \Delta t^2 [\text{id} - \alpha^2 \Delta t^2 \mathcal{A}]^{-1} \mathcal{F}(\mathbf{z}^n), \quad (19)$$

where id denotes the identity operator. This scheme is symplectic in the following sense. Consider the symplectic leapfrog scheme

$$\mathbf{q}^{n+1} - 2\mathbf{q}^n + \mathbf{q}^{n-1} = -\Delta t^2 \mathbf{M}^{-1} \mathbf{F}(\mathbf{q}^n)$$

for a Newtonian system with conservative force $\mathbf{F}(\mathbf{q})$, mass matrix \mathbf{M} and position vector \mathbf{q} . If we formally identify $\mathbf{q} = \mathbf{z}$, $\mathbf{M} = \text{id} - \alpha^2 \Delta t^2 \mathcal{A}$, $\mathbf{F}(\mathbf{q}) = -\mathcal{F}(\mathbf{z})$, then the leapfrog scheme becomes equivalent to (19).

To illustrate the linearly implicit method (19), apply it to the semi-linear wave equation (1). Set $\mathcal{A} = \partial_x^2$ and $\mathcal{F}(u) = u_{xx} - f(u)$, then the discretization yields the abstract numerical scheme

$$u^{n+1} - 2u^n + u^{n-1} = \Delta t^2 [\text{id} - \alpha^2 \Delta t^2 \partial_x^2]^{-1} [u_{xx} - f(u)], \quad \alpha \geq \frac{1}{2}.$$

The properties of these schemes applied to linear PDEs can be analyzed in some detail.

4.2 Linear Analysis of the Implicit Midpoint Method

In this subsection attention will be restricted to discretizations applied to the linearized wave equation

$$u_{tt} = u_{xx} - au, \quad \text{with } a > 0.$$

A Fourier transform *ansatz* in space leads to the differential equation

$$\frac{d^2}{dt^2} \hat{u} = -k^2 \hat{u} - a \hat{u}$$

where k is the wave number. For simplicity assume a delta function initial condition (in wave number space) so

$$u(x, t) = \hat{u}(t) \Re\{u_0 e^{ikx}\}.$$

Taking oscillatory solutions in time with frequency ω , i.e.

$$\frac{d^2}{dt^2} \hat{u} = -\omega^2 \hat{u},$$

leads to the dispersion relation

$$\omega^2 = k^2 + a$$

or, equivalently, $\omega(k) = \pm\sqrt{k^2 + a}$.

Now discretize the linear wave equation by the implicit midpoint/trapezoidal method. The resulting numerical time-stepping method is equivalent to

$$\hat{u}^{n+1} - 2\hat{u}^n + \hat{u}^{n-1} = -\Delta t^2(k^2 + a)\hat{u}^n - \frac{\Delta t^2}{4}(k^2 + a) [\hat{u}^{n+1} - 2\hat{u}^n + \hat{u}^{n-1}].$$

The behavior of such a method is best understood in terms of its numerical dispersion relation. Since the implicit midpoint method is symplectic, we may assume that

$$\hat{u}^{n+1} = e^{i\Omega_{\Delta t} \Delta t} \hat{u}^n,$$

where $\Omega_{\Delta t}$ is the ‘numerical’ frequency of the solution. Substituting this formula into the scheme and after a few manipulations with trigonometric functions, one finds the equivalence

$$\frac{4}{\Delta t^2} \tan^2 \left(\frac{\Omega_{\Delta t}(k) \Delta t}{2} \right) = k^2 + a,$$

or, equivalently,

$$\frac{\omega(k)\Delta t}{2} = \tan \left(\frac{\Omega_{\Delta t}(k)\Delta t}{2} \right). \quad (20)$$

This result holds more generally: given a linear system with a dispersion relation $\omega(k)$, discretization by the implicit midpoint/trapezoidal method leads to a numerical dispersion relation $\Omega_{\Delta t}(k)$ determined by (20). The largest possible numerical frequency is determined by

$$\lim_{|\omega(k)\Delta t| \rightarrow \infty} |\Omega_{\Delta t}(k)\Delta t| = \pi.$$

We also note that $\Omega_{\Delta t}(k)$ inherits the monotonicity of $\omega(k)$. Hence the numerical group velocity

$$V_g = \frac{d\Omega_{\Delta t}}{dk}.$$

has the same sign as the analytic group velocity

$$v_g = \frac{d\omega}{dk}.$$

The issue of group velocity does not arise in the ODE context and is an important issue in the PDE context. The group velocity characterizes the speed of energy transport in wave packets and its sign determines the *direction* of energy transport [147, Chapter 11]. Therefore an important property of a numerical scheme is that it reproduce the direction of energy transport, and track as closely as possible the magnitude of the group velocity.

This analysis can be repeated for the scheme (19) with $\mathcal{A}u = u_{xx} - au$, i.e.

$$\hat{u}^{n+1} - 2\hat{u}^n + \hat{u}^{n-1} = -\Delta t^2(k^2 + a)\hat{u}^n - \alpha^2\Delta t^2(k^2 + a) [\hat{u}^{n+1} - 2\hat{u}^n + \hat{u}^{n-1}],$$

with $\alpha \geq 1/2$. We first recall that the scheme is equivalent to

$$\hat{u}^{n+1} - 2\hat{u}^n + \hat{u}^{n-1} = -\Delta t^2 \frac{\omega(k)^2}{1 + \alpha^2\Delta t^2\omega^2(k)} \hat{u}^n$$

This scheme in turn is equivalent to a leapfrog discretization of an equation with frequency $\tilde{\omega}$, where

$$\tilde{\omega}^2 = \frac{\omega(k)^2}{1 + \alpha^2\Delta t^2\omega^2(k)}.$$

The standard numerical dispersion relation for the leapfrog method yields

$$\sin^2\left(\frac{\Delta t\Omega_{\Delta t}(k)}{2}\right) = \frac{\Delta t^2\tilde{\omega}^2}{4} = \frac{\Delta t^2\omega(k)^2}{4 + 4\alpha^2\Delta t^2\omega^2(k)}$$

and the largest numerical frequency in absolute value is determined by the relation

$$\sin\left(\frac{|\Delta t\Omega_{\Delta t}(k)|}{2}\right) = \frac{1}{2\alpha},$$

which has a unique solution for $\alpha \geq 1/2$. Note that the sign of the analytic group velocity is again preserved for any value of $\alpha \geq 1/2$. The scheme is also second order accurate for all wave numbers k with $\Delta t\omega(k) \rightarrow 0$.

When the scheme is applied to the semi-linear wave equation (1), it turns out that $\alpha = 1/\sqrt{2}$ is a good choice to avoid the potentially unstable 1:3 and 1:4 resonances of the leapfrog method near stationary solutions for any choice of Δt . See the work by SKEEL & SRINIVAS [131] and MA, IZAGUIRRE & SKEEL [94] on numerically induced resonance instabilities.

We also wish to point out that the fully implicit midpoint method can be unstable when applied with large time-steps compared to the dynamical time-scales present in the model equation. See GONZALEZ AND SIMO [55], MANDZIUK & SCHLICK [96], and ASCHER & REICH [5] for theoretical results. Energy conserving methods have been proposed as a remedy (see, for example, GONZALEZ [54] and [106]), but lead to fully implicit methods.

4.3 Equivalent Leapfrog Time-Stepping for Regularized Shallow-Water Equations

The discussion from the previous section can be extended to the shallow water equations (13), which are a prototype model for atmospheric fluid dynamics. An important issue in atmospheric fluid dynamics is the treatment of poorly resolved inertia-gravity waves. To circumvent the strict limitations imposed via the CFL condition on the maximum time step of explicit integration methods, most operational codes make use of some implicitness. At each time step, fully implicit methods require the solution of a nonlinear system of equations, whereas linearly implicit methods require only the solution of a linear system. An alternative strategy has been proposed in the context of the Hamiltonian Particle-Mesh (HPM) method (see, e.g. [45] and [49]), which is based on applying a regularization procedure to the continuous governing equations that renders them suitable for explicit integration.

More specifically, it has been shown by FRANK ET AL [51] that, on a linearized equation level and zero mean advection, a trapezoidal rule discretization of the shallow water equations is essentially equivalent to the leapfrog discretization of the regularized equations

$$\frac{\partial^2 \bar{\mathbf{x}}}{\partial t^2} + f \mathbf{k} \times \frac{\partial \bar{\mathbf{x}}}{\partial t} + g \nabla_{\mathbf{x}} (\mathcal{S} * h) = \mathbf{0} \quad (21)$$

with

$$\mathcal{S} * h = (1 - \alpha^2 \nabla_{\mathbf{x}}^2)^{-1} h$$

provided that

$$\alpha^2 = \frac{gH\Delta t^2}{4}, \quad \frac{f^2 \Delta t^2}{4} \ll 1,$$

where H denotes the mean layer depth of the fluid.

To see this, we set $f = 0$ for simplicity and state that the linearized equations under zero mean advection can be written as

$$\bar{\mathbf{x}}_{tt} = -g \nabla_{\mathbf{x}} h, \quad h = H(1 - \bar{x}_x - \bar{y}_y).$$

These equations give rise to the wave equation

$$h_{tt} = gH(h_{xx} + h_{yy})$$

and the regularized form is given by

$$h_{tt} = gH\mathcal{S} * (h_{xx} + h_{yy}).$$

An equivalent formulation is provided by

$$\bar{\mathbf{x}}_{tt} = -g \nabla_{\mathbf{x}} (\mathcal{S} * h), \quad h = H(1 - \bar{x}_x - \bar{y}_y),$$

which serves as a motivation for the formulation (21).

It should be noted that the regularized equations (21) can be derived from a Lagrangian variational principle. A leapfrog discretization of the regularized equations is given by

$$\begin{aligned} \frac{\bar{\mathbf{x}}^{n+1} - 2\bar{\mathbf{x}}^n + \bar{\mathbf{x}}^{n-1}}{\Delta t^2} + f \mathbf{k} \times \frac{\bar{\mathbf{x}}^{n+1} - \bar{\mathbf{x}}^{n-1}}{2\Delta t} &= -g \nabla_{\mathbf{x}} (\mathcal{S} * h^n), \\ h^n &= \sum_{kl} m_{kl} \psi(\cdot - \bar{\mathbf{x}}_{kl}^n). \end{aligned}$$

A disadvantage of the formulation (21) is that geostrophic balance, which is defined by

$$f \mathbf{k} \times \frac{\partial \bar{\mathbf{x}}}{\partial t} + g \nabla_{\mathbf{x}} h \approx \mathbf{0},$$

gets perturbed by the regularization operator. A revised regularization that addresses this shortcoming has been proposed by WOOD, STANFORTH & REICH [149]. A semi-Lagrangian implementation of these improved equations can be found in [121, 132].

In related work, WINGATE [148], compared the α -Euler regularization (see, for example, HOLM [65]) to dispersive effects of implicit time-stepping methods.

We finally wish to mention the work of COTTER & REICH [35, 36] on the long time preservation of geostrophic balance for large scale atmospheric flow regimes under the HPM method.

5 Variational Integrators and the Cartan Form

When an ODE or PDE is generated by a Lagrangian, instead of transforming to the Hamiltonian setting, one can discretize the Lagrangian directly, and then use a discrete variational principle. The fundamental geometric object associated with a Lagrangian is the Cartan form, and it is therefore at the center of a strategy for geometric integration.

For ODEs, the Cartan form associated with $\int L(t, \mathbf{q}, \mathbf{v})dt$ with $\mathbf{q} \in Q$ and $\mathbf{v} := \dot{\mathbf{q}}$ is

$$\theta_{\mathcal{L}} = L dt + L_{\mathbf{v}}(d\mathbf{q} - \mathbf{v}dt).$$

It is a semi-basic one-form on $TQ \times \mathbb{R}$. A geometric view of the Euler-Lagrange equations for L is given by requiring X to satisfy $X \lrcorner d\theta_{\mathcal{L}} = 0$, where X is a vector field on $TQ \times \mathbb{R}$.

Once the Lagrangian is discretized a strategy is needed to recover the discrete Cartan form. In a pioneering paper MARS DEN, PATRICK & SHKOLLER [98] showed that by discretizing the Lagrangian with free variations at the boundary, the Cartan form shows up in the boundary variation. This theory has been extensively developed in the ODE setting and a review is given in MARS DEN & WEST [102].

For PDEs this strategy works when there is a well-defined Cartan form. One class of PDEs where the theory is most successful is scalar first-order field theories with non-degenerate Lagrangian. For a field $q(x, t)$ with $(x, t) \in \mathbb{R}^2$, a Lagrangian $\mathcal{L} = \int dt \int dx L(t, x, q, q_t, q_x)$ is non-degenerate when

$$\det \begin{bmatrix} \frac{\partial^2 L}{\partial q_t^2} & \frac{\partial^2 L}{\partial q_t \partial q_x} \\ \frac{\partial^2 L}{\partial q_x \partial q_t} & \frac{\partial^2 L}{\partial q_x^2} \end{bmatrix} \neq 0.$$

The Lagrangian for the semi-linear wave equation (7) is in this class of Lagrangians. However, neither the Lagrangian for the KdV equation (18) nor the Lagrangian for the shallow water equations is in this class.

For scalar first-order field theories the Cartan form in local coordinates is

$$\theta_{\mathcal{L}} = \frac{\partial L}{\partial q_t} dq \wedge dx - \frac{\partial L}{\partial q_x} dq \wedge dt + \left(L - q_t \frac{\partial L}{\partial q_t} - q_x \frac{\partial L}{\partial q_x} \right) dt \wedge dx. \quad (22)$$

In [98] it is shown that a range of variational integrators can be constructed for the semilinear wave equation which preserve a discrete version of the Cartan form (22).

One weakness of variational integrators is that the geometry – which is used as a basis for geometric integrator – is dictated by the Lagrangian. Hence generalization of variational integrators to higher order field theories, vector valued fields, systems with constraints, and singular Lagrangians will depend on the existence of a Cartan form or a generalization of it. At present, almost all studies which use the Cartan form restrict attention to first-order field theories – either explicitly or implicitly.

There are many papers in the field theory literature which propose generalizations of the Cartan form, but the results are not encouraging. A good overview of the issues involved is given by GOTAY [56]. See also [40], [57] and [9] for further discussion and references.

Even though the geometric aspects of Lagrangian field theory for higher order fields are not entirely satisfactory in general, there are specific generalizations and special classes of Lagrangians where one can proceed. Examples are variational integrators for second-order field theory (KOURNABAEVA & SHKOLLER [81]), variational integrators for continuum mechanics and constrained PDEs (MARS DEN, PEKARSKY, SHKOLLER & WEST [99]), construction of variational integrators for the nonlinear Schrödinger equation (CHEN & QIN [32]), and variational integrators for higher-order differential equations (SUN & QIN [136]). One of the great successes of variational integrators for PDEs is in the application to systems with discontinuities. An example of this is

the work of FETEAU, MARSDEN, ORTIZ & WEST [41] on simulating collision of bodies in solid mechanics. A review of recent developments in the theory and application of variational integrators for PDEs is given by LEW, MARSDEN, ORTIZ & WEST [89].

The combination of variable time stepping and symplectic integrators has always been a problem area in geometric integration [85]. However it has been known since the work of LEE [83, 84] that variable time stepping could be incorporated into discrete mechanics – and energy could be conserved as well. In the ODE case this idea has been combined with variational integrators to design algorithms that conserve symplecticity, momentum and energy [78]. See also [86] and [30] where further generalization is obtained, and where the role of the discrete Cartan form is emphasized. The idea of variable time stepping has an immediate generalization to field theory and results of this type are reported by CHEN [27] and GUO & WU [58]. However, no backward error analysis is currently available for these methods and there are potential difficulties with the choice of step-size and its numerical implementation.

A related development is the idea of asynchronous variational integrators of LEW, MARSDEN, ORTIZ & WEST [88]. In the basic model, the time step is constant in time but can vary across the spatial mesh. Book-keeping goes up by an order of magnitude for these methods (see §4.3 of [88]) but are relatively efficient and show excellent discrete conservation of momentum. However, multi-time-step methods are susceptible to resonance-induced instabilities which are not yet fully understood (see [10, 61, 85] and page 187 of [88]).

The problem of symplectic and multi-symplectic variational discretizations can be approached from a purely topological viewpoint. For example GUO & WU [58] starting with a regular Lagrangian prove using co-homology that the necessary and sufficient condition for – either continuous or discrete – conservation of symplecticity is that the corresponding Euler-Lagrange one-form be closed (see Theorem 3 on page 5994 for the continuum case, and Theorem 4 on page 6000 for the discrete case).

Backward error analysis of variational integrators for ODEs is done by analogy with symplectic integrators: when the Lagrangian is non-degenerate, there is a duality with the Hamiltonian side and one deduces the existence of a modified energy (see §3.5 and the footnote on page 172 of [89]). However, a backward error analysis purely on the Lagrangian side has not been forthcoming.

There are other forms of error analysis which can be applied directly to the Lagrangian. MÜLLER & ORTIZ [112] and MAGGI & MORINI [95] use Γ -convergence to prove convergence of the discrete Lagrangian sum to the continuum Lagrangian. However this theory has – so far – only been applied to ODEs, requires strong hypotheses on the Lagrangian, and does not provide any information on ‘geometric’ error.

For PDEs, backward error analysis for variational integrators is still in its infancy. In a pioneering paper, OLIVER, WEST & WULFF [115] use backward error analysis to study the approximation properties of variational integrators for the semi-linear wave equation (1). When $f(u)$ is analytic they prove that the discrete momentum is conserved up to an error which is exponentially small in the spatial grid size. However the proofs still rely extensively on the Hamiltonian formulation of the semilinear wave equation.

6 Discretizing Multi-Symplectic Hamiltonian PDEs

In this section, discretization of multi-symplectic Hamiltonian PDEs is considered taking the canonical form (15) as a starting point. The principle geometric property of (15) is conservation of symplecticity, and therefore the strategy is to construct discretizations that conserve a discrete analogue.

A multi-symplectic integrator is defined in BRIDGES & REICH [23] to be a discretization which

preserves discrete conservation of symplecticity of a general form

$$\delta_t^+ \omega_i^n + \delta_x^+ \kappa_i^n = 0, \quad (23)$$

where δ_t^+ and δ_x^+ represent the (abstract) time and space discretization operators respectively. More precisely, one should apply discretization schemes to (15) and (16) and determine whether the resulting discrete symplectic conservation law is satisfied by the discretization of (15). Similar to symplectic ODE methods, only compact differencing methods (i.e. 'one-step methods' in space and time) satisfying (23) should be called multi-symplectic.

Another approach to this is to work directly with the discrete system, and use the concept of discrete multi-symplecticity introduced by HYDON [72]: given a system on a lattice, a condition for multi-symplecticity is deduced without reference to a continuum system.

Yet another approach is to view (15) as generated by Hamilton's principle. Introduce the Lagrangian

$$\mathcal{L} = \int dt \int dx \left[\frac{1}{2} \langle \mathbf{K} \mathbf{z}_t, \mathbf{z} \rangle + \frac{1}{2} \langle \mathbf{L} \mathbf{z}_x, \mathbf{z} \rangle - S(\mathbf{z}) \right], \quad (24)$$

then the first variation results in (15). This formulation is used in [72] for a generalization of multi-symplectic Noether theory. CHEN [29] uses the formulation (24) as a basis for a new definition of multi-symplectic integrator. CHEN discretizes the Lagrangian (24) using a variational integrator and then deduces a Cartan form from boundary variations, and shows that it leads to discrete conservation of symplecticity. However, surprisingly discrete conservation of symplecticity obtained from the discrete Cartan form does not always agree with that obtained directly from (23). The reason is simple: the two approaches agree only when the continuum Stokes theorem implies discrete Stokes theorem. It is easy to construct discretizations even for one-dimensional base manifolds that do not satisfy a discrete Stokes theorem: see CASTILLO ET AL [26] for examples and references. In general, discrete Stokes theorem is an additional geometric property that needs to be determined for – or derived as a part of – multi-symplectic discretizations.

The most widely used strategy for developing discretizations for (15) is to concatenate one-dimensional schemes. For example, applying the implicit midpoint rule to the PDE (15) in both space and time yields

$$\mathbf{K} \delta_t^+ \mathbf{z}_{i+1/2}^n + \mathbf{L} \delta_x^+ \mathbf{z}_i^{n+1/2} = \nabla_{\mathbf{z}} S \left(\mathbf{z}_{i+1/2}^{n+1/2} \right), \quad (25)$$

where we define the edge midpoint approximations

$$\mathbf{z}_i^{n+1/2} = \frac{1}{2} (\mathbf{z}_i^{n+1} + \mathbf{z}_i^n), \quad \mathbf{z}_{i+1/2}^n = \frac{1}{2} (\mathbf{z}_{i+1}^n + \mathbf{z}_i^n),$$

the cell center approximation

$$\mathbf{z}_{i+1/2}^{n+1/2} = \frac{1}{4} (\mathbf{z}_{i+1}^{n+1} + \mathbf{z}_i^{n+1} + \mathbf{z}_{i+1}^n + \mathbf{z}_i^n),$$

and the finite difference approximations

$$\delta_t^+ \mathbf{z}_{i+1/2}^n = \frac{1}{\Delta t} (\mathbf{z}_{i+1/2}^{n+1} - \mathbf{z}_{i+1/2}^n), \quad \delta_x^+ \mathbf{z}_i^{n+1/2} = \frac{1}{\Delta x} (\mathbf{z}_{i+1}^{n+1/2} - \mathbf{z}_i^{n+1/2}).$$

This scheme is an example of a 'box scheme'. The earliest reference to the use of a box scheme is PREISSMAN [117] who introduced it for the shallow water equations. We therefore will refer to (25) as the Preissman box scheme. KELLER [79] introduced a similar box scheme for parabolic problems. Independently, WENDROFF (see [111]) proposed a related box scheme for hyperbolic problems. The Preissman box scheme (25) exactly preserves a discrete multi-symplectic conservation law [23].

The Preissman box scheme has a number of nice properties and has been the most successful of the multi-symplectic integrators particularly when modelling wave propagation (e.g. ZHAO & QIN [152], ASCHER & MCLACHLAN [6], HONG & LIU [69], WANG, WANG & QIN [143], WANG, WANG, YANG & WANG [144]). The box scheme has been generalized to the case of space dimension ≥ 2 by HONG & QIN [70] and LIU & QIN [92]. Since the box scheme (25) is implicit in time particular care is needed to solve the resulting (possibly nonlinear) equations including the definition of appropriate boundary conditions.

The Preissman box scheme is second order accurate in space and time. Higher order box schemes can be constructed by concatenating higher order implicit Gauss-Legendre Runge Kutta methods. This was first done by REICH [120] and extended to partitioned GLRK methods by HONG, LIU & SUN [67]. This theory is developed in more detail in an application to nonlinear Dirac equations by HONG & LI [66].

One of the most successful applications of multi-symplectic integrators is to the nonlinear Schrödinger equation (ISLAS, KARPEEV & SCHÖBER [74], CHEN, QIN & TANG [34], ISLAS & SCHÖBER [75], SUN & QIN [135], HONG & LIU [68]). These integrators seem to have several magic properties when applied to NLS. For example, it is shown by ISLAS & SCHÖBER [76] that backward error analysis applied to the Preissman box scheme discretization of NLS leads to the modified equation (to leading order)

$$iA_t + A_{xx} + 2|A|^2A + \frac{i}{24}\Delta t^2 A_{ttt} + \frac{1}{12}\Delta x^2 A_{xxx} = 0.$$

The correction term is of order $\Delta t^2 + \Delta x^2$ and just brings in higher order dispersion. The modified PDE is also Hamiltonian and multi-symplectic.

When periodic boundary conditions are used, spectral methods can be appealing [42]. Multi-symplectic spectral discretizations have been proposed by BRIDGES & REICH [24], CHEN [28] and CHEN & QIN [31]. They show robust behaviour and excellent energy and momentum conservation, but a comparison with finite-difference based methods has not been carried out.

Other multi-symplectic discretizations that have been proposed are: schemes for Boussinesq models for water waves (HUANG, ZENG & QIN [71]), multi-symplectic finite-volume and finite-element methods (REICH [119], ZHEN, BAI, LI & WU [153]), multi-symplectic schemes for Maxwell's equations [134], higher-order schemes constructed using composition and other methods (SUN & QIN [137, 138], WANG & QIN [145, 146], WANG & WANG [142], CHEN & QIN [33]).

Backward error analysis for Hamiltonian ODEs is one of the great triumphs of geometric integration. Backward error analysis for multi-symplectic PDEs presents several challenges, and requires a new way of thinking, because the symplectic group structure of ODEs is lost. There has been some progress towards a backward error analysis for the general class of multi-symplectic PDEs (15) by MOORE & REICH [108, 109]. Rather than develop a theory for a modified Hamiltonian, they propose a theory for a modified symplectic structure. This theory is developed in detail for explicit symplectic Euler in space and time in [108] and in the PhD thesis of MOORE [107]. The matrices \mathbf{K} and \mathbf{L} are split so that

$$\mathbf{K} = \mathbf{K}_+ + \mathbf{K}_- \quad \text{and} \quad \mathbf{L} = \mathbf{L}_+ + \mathbf{L}_-,$$

with

$$\mathbf{K}_+^T = -\mathbf{K}_- \quad \text{and} \quad \mathbf{L}_+^T = -\mathbf{L}_-.$$

The Euler box scheme can then be represented in the form

$$\mathbf{K}_+ \delta_t^+ \mathbf{z}_i^n + \mathbf{K}_- \delta_t^- \mathbf{z}_i^n + \mathbf{L}_+ \delta_x^+ \mathbf{z}_i^n + \mathbf{L}_- \delta_x^- \mathbf{z}_i^n = \nabla_{\mathbf{z}} S(\mathbf{z}_i^n),$$

where δ_t^+ , δ_x^+ are defined as before and δ_t^- , δ_x^- are the corresponding backward differencing operators [111]. It is shown in [108] that this scheme is multi-symplectic. The modified multi-symplectic PDE associated with this scheme to leading order is

$$\mathbf{K}\mathbf{z}_t + \frac{\Delta t}{2}(\mathbf{K}_+ - \mathbf{K}_-)\mathbf{z}_{tt} + \mathbf{L}\mathbf{z}_x + \frac{\Delta x}{2}(\mathbf{L}_+ - \mathbf{L}_-)\mathbf{z}_{xx} = \nabla_{\mathbf{z}}S(\mathbf{z}).$$

In contrast to modified equations for ODEs, here the Hamiltonian function is unchanged, but higher order derivatives are generated in the multi-symplectic structure. Note also the symmetry in the error terms for x and t . MOORE & REICH then show that this equation has a new multi-symplectic structure on a higher-dimensional phase space. This scheme can be continued, in principle, to any order (see page 645 of [108]). Another useful outcome of this theory is a modified conservation law for energy and momentum. See §5.3 of [108] for the details of this theory applied to the nonlinear wave equation.

Let us finally consider the non-compact discretization

$$\Delta t^{-1}\mathbf{K}(\mathbf{z}_i^{n+1} - \mathbf{z}_i^{n-1}) + \Delta x^{-1}\mathbf{L}(\mathbf{z}_{i+1}^n - \mathbf{z}_{i-1}^n) = 2\nabla_{\mathbf{z}}S(\mathbf{z}_i^n).$$

This scheme satisfies a discrete conservation law of symplecticity of the form (23) but would not be called multi-symplectic because the non-compact nature of its spatial and temporal discretizations [107, 47].

6.1 Discrete Energy and Momentum Conservation

How well do multi-symplectic integrators conserve local or global momentum and energy? In this subsection some results on this are summarized. There is still much to be done in this area however.

When a uniform mesh is used there is no reason to expect discrete energy or momentum to be conserved exactly. However there is a special case of interest. It is proved in [23] that if the covariant Hamiltonian function $S(\mathbf{z})$ is a quadratic function of \mathbf{z} and the box scheme is used, then both discrete energy and discrete momentum are conserved to machine accuracy.

When $S(\mathbf{z})$ is super-quadratic, and the box scheme (25) is used, global momentum (sum over space lattice points) is still conserved to machine accuracy since it is a quadratic invariant. However the local momentum conservation law (LMCL) is not conserved.

When $S(\mathbf{z})$ is super-quadratic the local energy conservation law (LECL) and the local momentum conservation law are generally well behaved, but the results are still incomplete. For the nonlinear Dirac equation HONG & LI [66] show that the LECL and LMCL grow algebraically with the mesh size and time step, when multi-symplectic Runge-Kutta methods are used. For the NLS equation ISLAS & SCHOBBER [76] show that LECL and LMCL grow quadratically in the time step when the box scheme is used.

Backward error analysis provides interesting information about modified energy and momentum conservation laws. General aspects of the theory of modified conservation laws is developed in MOORE & REICH [109]. ISLAS & SCHOBBER [76] construct the modified LECL and LMCL for the box scheme applied to the NLS equation. For example the modified LECL is

$$\frac{\partial}{\partial t} \left[E + \frac{\Delta t^2}{24} \mathbf{z}_{tt}^T \mathbf{K} \mathbf{z}_t + \frac{\Delta x^2}{48} \mathbf{z}_{xx}^T \mathbf{L} \mathbf{z}_x \right] + \frac{\partial}{\partial x} \left[F + \frac{\Delta x^2}{48} \mathbf{z}_{xt}^T \mathbf{L} \mathbf{z}_x \right] = 0.$$

Numerical evaluation of this modified LECL shows that it is satisfied to fourth order in Δt , confirming the order estimate in the backward error analysis.

It is tempting to replace the local conservation laws for energy and momentum by contour integrals. For example, replace the energy conservation law by

$$\oint F dt - E dx = 0. \quad (26)$$

Clearly, in the continuum setting this formulation is equivalent to $E_t + F_x = 0$ (assuming the necessary smoothness of the functions involved). However, the discrete form of the the integral (26) may not be equivalent to the direct discretization of $E_t + F_x$ – unless there is a discrete Stokes theorem. A discrete Stokes Theorem does not imply that energy is conserved, merely that discretizing the contour integral $\oint F dt - E dx$ is equivalent to the discretization of $E_t + F_x$.

6.2 Analysis of the Discretized Dispersion Relation

In this section, we summarize a few results on multi-symplectic discretization methods for the class of linear PDEs

$$\mathbf{K} \mathbf{z}_t + \mathbf{L} \mathbf{z}_x = \mathbf{A} \mathbf{z} \quad (27)$$

where \mathbf{A} is a symmetric matrix. Since we are interested in wave-like solutions we seek (complex-valued) solutions, i.e.

$$\mathbf{z}(x, t) = e^{i(kx + \omega t)} \mathbf{a}. \quad (28)$$

Here, k denotes the wave number and ω denotes the wave frequency, which must satisfy the dispersion relation [13]

$$\mathcal{D}(\omega, k) := \det(i\omega \mathbf{K} + ik \mathbf{L} - \mathbf{A}) = 0. \quad (29)$$

It is important to note that the matrix used in this calculation is self-adjoint, i.e., $\overline{\mathcal{D}(\omega, k)} = \mathcal{D}(\bar{\omega}, \bar{k})$, from which it is immediate that $0 = \mathcal{D}(\omega, k) = \mathcal{D}(\bar{\omega}, k)$ for real k . Hence, for any given real k , solutions ω of the dispersion relation are either real or come in complex-conjugate pairs meaning there is no diffusion [147, Chapter 11].

With the dispersion relation, one can write the frequency as a function of the wave number, such that

$$\mathcal{D}(\omega, k) = 0 \quad \iff \quad \omega = \omega(k),$$

at least locally. Then, depending on the function \mathcal{D} , there may be multiple frequencies ω_i for every k , corresponding to different modes. One could also pose the reverse question and ask how many different wave numbers k can give rise to a given frequency ω .

We wish to extend the linear dispersion analysis from previous sections to multi-symplectic integration methods. Applying, for example, the Preissman box scheme to the linear PDE (27) yields

$$\mathbf{K} \delta_t^+ \mathbf{z}_{i+1/2}^n + \mathbf{L} \delta_x^+ \mathbf{z}_i^{n+1/2} = \mathbf{A} \mathbf{z}_{i+1/2}^{n+1/2}. \quad (30)$$

Based upon the results of [109], the modified equation for the linear PDE (27) can be stated explicitly as

$$\mathbf{K} \left(\mathbf{z}_t - \frac{\tau^2}{3} \mathbf{z}_{ttt} + \frac{2\tau^4}{15} \mathbf{z}_{tttt} - \dots \right) + \mathbf{L} \left(\mathbf{z}_x - \frac{\chi^2}{3} \mathbf{z}_{xxx} + \frac{2\chi^4}{15} \mathbf{z}_{xxxx} - \dots \right) = \mathbf{A} \mathbf{z}. \quad (31)$$

Here we introduced the notation

$$\tau = \frac{\Delta t}{2} \quad \text{and} \quad \chi = \frac{\Delta x}{2},$$

which we will use through the remainder of this section.

The expansion (31) formally yields a higher order linear PDE and we may substitute a standard solution *ansatz* of the form

$$\mathbf{z}(x, t) = e^{i(\Omega t + Kx)} \mathbf{a}$$

into the equation. This yields

$$\left(\mathbf{iK} \left(\Omega + \frac{\tau^2 \Omega^3}{3} + \frac{2\tau^4 \Omega^5}{15} + \dots \right) + \mathbf{iL} \left(K + \frac{\chi^2 K^3}{3} + \frac{2\chi^4 K^5}{15} + \dots \right) - \mathbf{A} \right) \mathbf{a} = \mathbf{0}.$$

Then, due to the identity

$$\tan(\theta) = \theta + \frac{\theta^3}{3} + \frac{2\theta^5}{15} + \dots,$$

we obtain

$$\left(\frac{\mathbf{i}}{\tau} \tan(\tau\Omega) \mathbf{K} + \frac{\mathbf{i}}{\chi} \tan(\chi K) \mathbf{L} - \mathbf{A} \right) \mathbf{a} = \mathbf{0} \quad (32)$$

(because the expansions in (31) converge). The modified equation can also be stated in closed form because the expansions in (31) converge and is given by

$$\frac{1}{\tau} \mathbf{K} \tanh(\tau \partial_t) \mathbf{z} + \frac{1}{\chi} \mathbf{L} \tanh(\chi \partial_x) \mathbf{z} = \mathbf{A} \mathbf{z}.$$

Furthermore, the following theorem follows immediately from (32).

Theorem 1 *The Preissman box scheme (30) preserves the analytic dispersion relation of the PDE, such that*

$$\mathcal{D}(\omega, k) = 0, \quad (33)$$

for \mathcal{D} as given in (29) with

$$\omega = \frac{\tan(\tau\Omega)}{\tau} \quad \text{and} \quad k = \frac{\tan(\chi K)}{\chi}, \quad (34)$$

for $-\frac{\pi}{2} < \tau\Omega < \frac{\pi}{2}$ and $-\frac{\pi}{2} < \chi K < \frac{\pi}{2}$. In other words, the numerical dispersion relation is given by

$$\mathcal{D}_N(\Omega, K) := \mathcal{D} \left(\frac{\tan(\tau\Omega)}{\tau}, \frac{\tan(\chi K)}{\chi} \right) = 0.$$

This result was first published by ASCHER & MCLACHLAN [6]. The numerical group velocity V_g is defined by

$$V_g = \frac{d}{dK} \Omega(K) = - \frac{\partial \mathcal{D}}{\partial k} \frac{\partial k}{\partial K} / \frac{\partial \mathcal{D}}{\partial \omega} \frac{\partial \omega}{\partial \Omega} = v_g \frac{\partial k}{\partial K} / \frac{\partial \omega}{\partial \Omega}.$$

Since both

$$\frac{\partial \omega}{\partial \Omega} > 0 \quad \text{and} \quad \frac{\partial k}{\partial K} > 0,$$

we have derived

Corollary 1 *The sign of the analytic group velocity v_g is preserved under the Preissman box scheme.*

These results explain the absence of parasitic waves in space and time for the Preissman box scheme for all Δt and Δx . A more detailed discussion of numerical dispersion relations of multi-symplectic methods including higher-order Gauss-Legendre Runge-Kutta methods can be found in [47]. We also mention the work of FRANK on numerical conservation of wave action by multi-symplectic methods [44].

7 Multi-Symplectic Discretizations on the TEA Bundle

A promising new direction in multi-symplectic discretization is the combination of discrete differential forms with multi-symplectic structure. In order to implement this idea, multi-symplectic PDEs have to be reformulated using differential forms. Since it is the base manifold that is discretized, the formulation requires differential forms on the base manifold (space time) [15].

For illustration take space-time to be (M, g) with $M = \mathbb{R}^2$ with a flat metric g (either Euclidean or Lorentzian) and standard volume form. Then a Hodge star operator \star and codifferential δ can be defined. We consider the elliptic equation

$$u_{xx} + u_{yy} + f(u) = 0.$$

A multi-symplectic formulation is provided by (3) with

$$\mathbf{K} = \begin{bmatrix} 0 & -1 & 0 & 0 \\ 1 & 0 & 0 & 0 \\ 0 & 0 & 0 & 1 \\ 0 & 0 & -1 & 0 \end{bmatrix}, \quad \mathbf{L} = \begin{bmatrix} 0 & 0 & -1 & 0 \\ 0 & 0 & 0 & -1 \\ 1 & 0 & 0 & 0 \\ 0 & 1 & 0 & 0 \end{bmatrix},$$

and S the algebraic function

$$S(\mathbf{z}) = \frac{1}{2}(p_1)^2 + \frac{1}{2}(p_2)^2 + F(u) \quad \text{with} \quad \mathbf{z} = (u, p_1, p_2, r)^T.$$

This formulation has a coordinate free representation

$$\begin{aligned} \delta \mathbf{p} &= f(u) \\ du + \delta R &= \mathbf{p} \\ d\mathbf{p} &= 0 \end{aligned} \tag{35}$$

where (u, \mathbf{p}, R) are elements in the total exterior algebra (TEA) of \mathbb{R}^2 . Details of multi-symplectic PDEs on the TEA bundle are developed in BRIDGES [15].

A discretization of (35) is carried out by using discrete differential forms [12, 63, 37] or difference forms [97]. To illustrate the discretization of the formulation (35), first consider the case of one-dimensional base manifold.

The Newtonian equation $q_{tt} = -V'(q)$ for scalar q can be formulated in a coordinate-free way as

$$dq = P \quad \text{and} \quad \delta P = V'(q) \tag{36}$$

where $dq := q_t dt$ and $\delta = -\star d\star$ is the codifferential with \star the Hodge star operator normalized by $\star dt = 1$ [15, 22]. Now introduce a discretization of time, with $q^n \approx q(n\Delta t)$ and approximate the differential forms by

$$\Delta^+ q^n = P^{n+1/2} \quad \text{and} \quad \delta^- P^{n+1/2} = V'(q^n)$$

Using difference forms with $\Delta t = h_1 \Delta^1$, where Δ^1 is a basis vector for discrete one forms and h_1 is a scale factor,

$$\Delta^+ q^n = (q^{n+1} - q^n) \wedge \Delta^1 = \frac{(q^{n+1} - q^n)}{h_1} \wedge h_1 \Delta^1,$$

and the simplest approximation of the one form $P^{n+1/2} \approx P((n+1/2)\Delta t)$ is

$$P^{n+1/2} = p^{n+\frac{1}{2}} \Delta t = p^{n+\frac{1}{2}} h_1 \Delta^1.$$

For the codifferential, recall that δ is the adjoint of d with respect to the Riemannian metric on the base manifold – integrated over time. Use the discrete analog:

$$\begin{aligned}
\sum_n P_{n+1/2} \wedge \star \Delta^+ q^n &= \sum_n \Delta^+ q^n \wedge \star P^{n+1/2} \\
&= \sum_n \Delta^+ (q^n \wedge \star P^{n-1/2}) - \sum_n q^n \wedge \Delta^- \star P^{n+1/2} \\
&= -\sum_n q^n \wedge \star \star \Delta^- \star P^{n+1/2} \\
&= \sum_n q^n \wedge \star \delta^- P^{n+1/2},
\end{aligned}$$

assuming suitable endpoint conditions, with $\delta^- = -\star \Delta^- \star$, where

$$\Delta^- q^n = (q^n - q^{n-1}) \wedge \Delta^1 = \frac{(q^n - q^{n-1})}{h_1} \wedge h_1 \Delta^1.$$

Applying this formula to $P^{n+1/2}$ results in

$$\delta^- P^{n+1/2} = \frac{(-p^{n+\frac{1}{2}} + p^{n-\frac{1}{2}})}{h_1}.$$

Combining these equations

$$q^{n+1} = q^n + h_1 p^{n+\frac{1}{2}} \quad \text{and} \quad p^{n+\frac{1}{2}} = p^{n-\frac{1}{2}} - h_1 V'(q^n).$$

This algorithm is just the staggered formulation of the Störmer-Verlet method deduced from the viewpoint of the geometry of time! However, this scheme is obtained by the simplest choice of discretization of the differential forms.

One of the curiosities of this formulation is that the one form $P = p(t)dt$ is different from the momentum in classical mechanics, it is closer to an impulse. The diagram below shows how the geometry of (36) differs from that of classical mechanics (cf. BRIDGES & LAWSON [22]).

$$\begin{array}{ccc}
& & \text{Vert } T^* \wedge (T^* M) \\
& & \downarrow \pi_{AV} \\
\mathbb{P} := T^* Q = T^* (\wedge^0(T^* M)) & & \wedge(T^* M) := \text{TEA} \\
& \searrow \pi_{QP} & \swarrow \pi_{T_0} \\
& Q := \wedge^0(T^* M) & \\
& \downarrow \pi_{MQ} & \\
& M &
\end{array}$$

In this diagram Q is one dimensional, and the left branch shows phase space for classical mechanics. On the right is the TEA formulation. An interesting aspect of the right branch is that the Hamiltonian function is clearly a section of the vertical part of $T^* \wedge (T^* M)$. See [22] for details of this structure.

These ideas generalize in a straightforward way to manifolds of dimension greater than one, and to manifolds with curvature [22, 20]. Consider the discretization of (35) using the theory of difference forms of MANSFIELD & HYDON [97]. Introduce a lattice for \mathbb{R}^2 ,

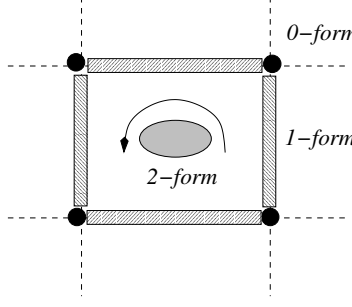

and discretize u as a zero form, \mathbf{p} as a one form and R as a two form, and introduce discretizations for d , Hodge star and δ .

Let $u^{i,j} = u(i\Delta x_1, j\Delta x_2)$ and define the two difference operators

$$\begin{aligned}\Delta^+ u^{i,j} &= (u^{i+1,j} - u^{i,j}) \wedge \Delta^1 + (u^{i,j+1} - u^{i,j}) \wedge \Delta^2, \\ \Delta^- u^{i,j} &= (u^{i,j} - u^{i-1,j}) \wedge \Delta^1 + (u^{i,j} - u^{i,j-1}) \wedge \Delta^2,\end{aligned}$$

where Δ^1 and Δ^2 are basis vectors for the one-forms, and $\Delta x_k = h_k \Delta^k$, $k = 1, 2$ with scaling factors h_1 and h_2 . Hodge star is defined by

$$\begin{aligned}\star 1 &= h_1 h_2 \Delta^1 \wedge \Delta^2, & \star h_1 h_2 \Delta^1 \wedge \Delta^2 &= 1, \\ \star h_1 \Delta^1 &= h_2 \Delta^2, & \star h_2 \Delta^2 &= -h_1 \Delta^1.\end{aligned}$$

Take the simplest discrete representation for the one-forms and two-forms:

$$\begin{aligned}\mathbf{p}^{i,j} &= p_1^{i+1/2,j} h_1 \Delta^1 + p_2^{i,j+1/2} h_2 \Delta^2, \\ R^{i+1/2,j+1/2} &= r^{i+1/2,j+1/2} h_1 h_2 \Delta^1 \wedge \Delta^2.\end{aligned}$$

For the codifferential proceed as in the one-dimensional case, and define the discrete codifferential δ^- to be the adjoint of Δ^- with respect to the induced inner product on $\mathbb{Z} \times \mathbb{Z}$. For example,

$$\sum_{i,j} \Delta^+ u^{i,j} \wedge \star \mathbf{p}^{i,j} = \sum_{i,j} u^{i,j} \wedge \star \delta^- \mathbf{p}^{i,j},$$

with

$$\delta^- \mathbf{p}^{i,j} = -\star \Delta^- \star \mathbf{p}^{i,j}.$$

Let us go through this definition in detail. We first find that

$$\star \mathbf{p}^{i,j} = p_1^{i+1/2,j} h_2 \Delta^2 - p_2^{i,j+1/2} h_1 \Delta^1.$$

Application of the discrete differential operator Δ^- leads to

$$\begin{aligned}\Delta^- \star \mathbf{p}^{i,j} &= \left(p_1^{i+1/2,j} - p_1^{i-1/2,j} \right) h_2 \Delta^2 \wedge \Delta^1 - \left(p_2^{i,j+1/2} - p_2^{i,j-1/2} \right) h_1 \Delta^1 \wedge \Delta^2 \\ &= - \left[\frac{p_1^{i+1/2,j} - p_1^{i-1/2,j}}{h_1} + \frac{p_2^{i,j+1/2} - p_2^{i,j-1/2}}{h_2} \right] h_1 h_2 \Delta^1 \wedge \Delta^2.\end{aligned}$$

The desired formula is then given by

$$\delta^- \mathbf{p}^{i,j} = - \left[\frac{p_1^{i+1/2,j} - p_1^{i-1/2,j}}{h_1} + \frac{p_2^{i,j+1/2} - p_2^{i,j-1/2}}{h_2} \right].$$

Substituting the discretized forms and the discrete operators Δ^+ , δ^- into the governing equations (35) results in

$$\begin{aligned} -\left(\frac{p_1^{i+1/2,j}-p_1^{i-1/2,j}}{h_1}\right) - \left(\frac{p_2^{j,j+1/2}-p_2^{i,j-1/2}}{h_2}\right) &= f(u^{i,j}), \\ \left(\frac{u^{i+1,j}-u^{i,j}}{h_1}\right) - \left(\frac{r^{i+1/2,j+1/2}-r^{i+1/2,j-1/2}}{h_2}\right) &= p_1^{i+1/2,j}, \\ \left(\frac{r^{i+1/2,j+1/2}-r^{i-1/2,j+1/2}}{h_1}\right) + \left(\frac{u^{i,j+1}-u^{i,j}}{h_2}\right) &= p_2^{i,j+1/2}, \\ -\left(\frac{p_2^{i+1,j+1/2}-p_2^{i,j+1/2}}{h_1}\right) + \left(\frac{p_1^{i+1/2,j+1}-p_1^{i+1/2,j}}{h_2}\right) &= 0. \end{aligned}$$

This discretization leads to a staggered box scheme, which is equivalent to the standard central difference approximation

$$\frac{u^{i+1,j} - 2u^{i,j} + u^{i-1,j}}{(\Delta x_1)^2} + \frac{u^{i,j+1} - 2u^{i,j} + u^{i,j-1}}{(\Delta x_2)^2} + f(u^{i,j}) = 0.$$

While the examples shown above are simple and lead to well known algorithms, there is a well-defined strategy for generalization: replace the continuum differential forms on the base manifold by discrete differential forms on the lattice version of the base manifold. It is straightforward to show that the above scheme satisfies discrete conservation of symplecticity [23]. This property and other generalizations are considered by BRIDGES & HYDON [20]. When the base manifold is covered by a logically rectangular grid, the ideas of mimetic differencing [128, 73] will also be useful for discretization.

Appendix

We give a brief description of the numerical experiment from §1. The Preissman box scheme (25) has been applied to the multi-symplectic formulation (14) of the wave equation (1) with $f \equiv 0$ (linear wave equation). The computational domain is $(x, t) \in [0, 20] \times [0, 20]$ with absorbing boundary conditions $u_t = u_x$ at $x = 0$ and $u_t = -u_x$ at $x = 20$. Initial conditions at time $t = 0$ are $v(x, 0) = 0$ and $u(x, 0) = \exp(-(x - 10)^2)$. The mesh-size is given by $\Delta x = 0.1$ and the step-size by $\Delta t = 0.1$, respectively. The boundary conditions are implemented using the equations

$$v_0^n = -w_0^n, \quad v_I^n = w_I^n, \quad \text{for all } n = 0, 1, 2, \dots$$

References

- [1] M.B. Abbott. *Computational Hydraulics*. Pitman Publishers, London, 1979.
- [2] M.B. Abbott and D.R. Basco. *Computational Fluid Dynamics*. Longman Scientific & Technical, Harlow, Essex, 1989.
- [3] A. Arakawa. Computational design for long-term numerical integration of the equations of fluid motion: Two-dimensional incompressible flow. Part I. *J. Comput. Phys.*, 1:119–143, 1966.
- [4] V.I. Arnold. *Mathematical Methods of Classical Mechanics*. Springer-Verlag, New York, 2nd edition, 1989.

- [5] U. Ascher and S. Reich. The midpoint scheme and variants for Hamiltonian systems: Advantages and pitfalls. *SIAM J. Sci. Comput.*, 21:1045–1065, 1999.
- [6] U.M. Ascher and R.I. McLachlan. Multisymplectic box schemes and the Korteweg-de Vries equation. *Appl. Numer. Math.*, 48:255–269, 2004.
- [7] A. Awane and M. Goze. *Pfaffian Systems and k-Symplectic Systems*. Kluwer Academic Publishers, Dordrecht, 2000.
- [8] G. Benetin and A. Giorgilli. On the Hamiltonian interpolation of near to the identity symplectic mappings with application to symplectic integration algorithms. *J. Stat. Phys.*, 74:1117–1143, 1994.
- [9] D.E. Betounes. Extension of the classical Cartan form. *Phys. Rev. D*, 29:599–606, 1984.
- [10] J.J. Biesiadecki and R.D. Skeel. Dangers of multiple time step methods. *J. Comput. Phys.*, 109:318–328, 1993.
- [11] C.K. Birdsall and A.B. Langdon. *Plasma Physics via Computer Simulations*. McGraw-Hill, New York, 1981.
- [12] A. Bossavit. Generalized finite differences in computational electromagnetics. *Progress in Electromagnetic Research, PIER*, 32:45–64, 2001.
- [13] T.J. Bridges. A geometric formulation of the conservation of wave action and its implications for signature and the classification of instabilities. *Proc. R. Soc. Lond. A*, 453(A):1365–1395, 1997.
- [14] T.J. Bridges. Multi-symplectic structures and wave propagation. *Math. Proc. Camb. Phil. Soc.*, 121:147–190, 1997.
- [15] T.J. Bridges. Canonical multi-symplectic structure on the total exterior algebra bundle. *Proc. Royal Soc. London A*, in press, 2006.
- [16] T.J. Bridges and G. Derks. Unstable eigenvalues and the linearization about solitary waves and fronts with symmetry. *Proc. R. Soc. Lond. A*, 455(A):2427–2469, 1999.
- [17] T.J. Bridges and G. Derks. The symplectic Evans matrix, and the instability of solitary waves and fronts. *Arch. Rat. Mech. Anal*, 156:1–87, 2001.
- [18] T.J. Bridges and G. Derks. Linear instability of solitary wave solutions of the Kawahara equation and its generalizations. *SIAM J. Math. Anal.*, 33:1356–1378, 2002.
- [19] T.J. Bridges, G. Derks, and G. Gottwald. Stability and instability of solitary waves of the fifth-order KdV equation: A numerical framework. *Physica D*, 172:190–216, 2002.
- [20] T.J. Bridges and P.E. Hydon. Covariant multi-symplectic discretizations on the total exterior algebra bundle. Technical report, University of Surrey, 2005.
- [21] T.J. Bridges, P.E. Hydon, and S. Reich. Vorticity and symplecticity in Lagrangian fluid dynamics. *J. Phys. A: Math. Gen.*, 38:1403–1418, 2005.
- [22] T.J. Bridges and J.K. Lawson. Symplectic discretization from the view of the cotangent bundle of time. Technical report, University of Surrey, 2005.

- [23] T.J. Bridges and S. Reich. Multi-symplectic integrators: Numerical schemes for Hamiltonian PDEs that conserve symplecticity. *Physics Letters A*, 284:184–193, 2001.
- [24] T.J. Bridges and S. Reich. Multi-symplectic spectral discretizations for the Zakharov-Kuznetsov and shallow-water equations. *Physica D*, 152:491–504, 2001.
- [25] F. Cantrijn, A. Ibort, and M. de León. On the geometry of multisymplectic manifolds. *J. Austr. Math. Soc. A*, 66:303–330, 1999.
- [26] J.E. Castillo, J.M Hyman, M. Shashkov, and S. Steinberg. Fourth- and sixth-order conservative finite difference approximations of the divergence and gradient. *Appl. Numer. Math.*, 37:171–187, 2001.
- [27] J.-B. Chen. Total variation in discrete multisymplectic field theory and multisymplectic-energy-momentum integrators. *Lett. Math. Phys.*, 61:63–73, 2002.
- [28] J.-B. Chen. Multisymplectic geometry, local conservation laws and a multisymplectic integrator for the Zakharov-Kuznetsov equation. *Lett. Math. Phys.*, 63:115–124, 2003.
- [29] J.-B. Chen. Variational formulation for multisymplectic Hamiltonian systems. *Lett. Math. Phys.*, 71:243–253, 2005.
- [30] J.-B. Chen, H.Y. Guo, and K. Wu. Total variation in Hamiltonian formalism and symplectic-energy conservation. *J. Math. Phys.*, 44:1688–1702, 2003.
- [31] J.-B. Chen and M.Z. Qin. Multi-symplectic Fourier pseudospectral method for the nonlinear Schrödinger equation. *Electron. Trans. Numer. Anal.*, 12:193–204, 2001.
- [32] J.-B. Chen and M.Z. Qin. A multisymplectic variational integrator for the nonlinear Schrödinger equation. *nmpde*, 18:523–536, 2002.
- [33] J.-B. Chen and M.Z. Qin. Multisymplectic composition integrators of high order. *J. Comput. Math.*, 21:647–656, 2003.
- [34] J.-B. Chen, M.Z. Qin, and Y.-F. Tang. Symplectic and multi-symplectic methods for the nonlinear Schrödinger equation. *Comput. Math. Appl.*, 43:1095–1106, 2002.
- [35] C.J. Cotter and S. Reich. Adiabatic invariance and applications: From molecular dynamics to numerical weather prediction. *BIT*, 44:439–455, 2004.
- [36] C.J. Cotter and S. Reich. Semi-geostrophic particle motion and exponentially accurate normal forms. Technical report, Universität Potsdam, Institut für Mathematik, 2005.
- [37] M. Desbrun, A.N. Hirani, M. Leok, and J.E. Marsden. Discrete exterior calculus. Technical report, California Institute of Technology, 2003.
- [38] M. Dixon and S. Reich. Symplectic time-stepping for particle methods. *GAMM Mitteilungen*, 27:9–24, 2004.
- [39] D.R. Durran. *Numerical Methods for Wave Equations in Geophysical Fluid Dynamics*. Springer-Verlag, Berlin, 1998.
- [40] H. E. Binz, H. Fischer and J. Śniatycki. *The Geometry of Classical Fields*. North Holland, Amsterdam, 1988.

- [41] R. Fetecau, J.E. Marsden, M. Ortiz, and M. West. Nonsmooth Lagrangian mechanics and variational collision integrators. *SIAM J. Appl. Dyn. Sys.*, 2:381–416, 2003.
- [42] B. Fornberg. *A Practical Guide to Pseudospectral Methods*. Cambridge University Press, 1998.
- [43] J. Frank. Geometric space-time integration of ferromagnetic materials. *Appl. Numer. Math.*, 48:307–322, 2004.
- [44] J. Frank. Conservation of wave action under multisymplectic discretizations. *J. Phys. A: Math. Gen.*, this volume, 2006.
- [45] J. Frank, G. Gottwald, and S. Reich. The Hamiltonian particle-mesh method. In M. Griebel and M.A. Schweitzer, editors, *Meshfree Methods for Partial Differential Equations*, volume 26 of *Lect. Notes Comput. Sci. Eng.*, pages 131–142, Berlin Heidelberg, 2002. Springer-Verlag.
- [46] J. Frank, W. Huang, and B. Leimkuhler. Geometric integrators for classical spin systems. *J. Comput. Phys.*, 133:160–172, 1997.
- [47] J. Frank, B.E. Moore, and S. Reich. Linear PDEs and numerical methods that preserve a multi-symplectic conservation law. *SIAM J. Sci. Comput.*, in press, 2006.
- [48] J. Frank and S. Reich. Conservation properties of Smoothed Particle Hydrodynamics applied to the shallow-water equations. *BIT*, 43:40–54, 2003.
- [49] J. Frank and S. Reich. The Hamiltonian particle-mesh method for the spherical shallow water equations. *Atmos. Sci. Lett.*, 5:89–95, 2004.
- [50] J. Frank and S. Reich. Energy-conserving semi-discretizations and spurious numerical reflections. Technical report, Universität Potsdam and CWI Amsterdam, 2005.
- [51] J. Frank, S. Reich, A. Staniforth, A. White, and N. Nigel. Analysis of a regularized, time-staggered discretization method and its link to the semi-implicit method. *Atmos. Sci. Lett.*, 6:97–104, 2005.
- [52] R.A. Gingold and J.J. Monaghan. Smoothed Particle Hydrodynamics: Theory and application to non-spherical stars. *Mon. Not. R. Astr. Soc.*, 181:375–389, 1977.
- [53] H. Goldstein, C. Pole, and J. Safko. *Classical Mechanics*. Addison Wesley, San Francisco, CA, 3rd edition, 2002.
- [54] O. Gonzalez. Time integration and discrete Hamiltonian systems. *Journal of Nonlinear Science*, 6:449–467, 1996.
- [55] O. Gonzalez and J.C. Simo. On the stability of symplectic and energy-momentum algorithms for nonlinear Hamiltonian systems with symmetry. *Computer Methods in Applied Mechanics and Engineering*, 134:197–222, 1996.
- [56] M.J. Gotay. A multisymplectic framework for classical field theory and the calculus of variations I. Covariant Hamiltonian formalism. In N. Francaviglia, editor, *Mechanics, Analysis and Geometry, 200 years after Lagrange*, pages 203–235, Amsterdam, 1991. North Holland.
- [57] M.J. Gotay, J.A. Isenberg, J.E. Marsden, and R. Montgomery. Momentum mappings and classical relativistic fields. Technical report, California Institute of Technology, 2002.

- [58] H.-Y. Guo and K. Wu. On variations in discrete mechanics and field theory. *J. Math. Phys.*, 44:5978–6004, 2003.
- [59] E. Hairer and Ch. Lubich. The life-span of backward error analysis for numerical integrators. *Numer. Math.*, 76:441–462, 1997.
- [60] E. Hairer and Ch. Lubich. Energy conservation by Störmer-type numerical integrators, G.F. Griffiths and G.A. Watson (eds.). In *Numerical Analysis 1999*, pages 169–190. CRC Press LLC, 2000.
- [61] E. Hairer, Ch. Lubich, and G. Wanner. *Geometric Numerical Integration*. Springer-Verlag, Berlin Heidelberg, 2002.
- [62] W. Hansen. Theorie zur Errechnung des Wasserstandes und der Strömung in Randmeeren nebst Anwendungen. *Tellus*, 8:289–300, 1956.
- [63] R. Hiptmair. Finite elements in computational electromagnetism. *Acta Numerica*, 11:237–339, 2002.
- [64] R.W. Hockney and J.W. Eastwood. *Computer Simulations Using Particles*. Institute of Physics Publisher, Bristol and Philadelphia, 1988.
- [65] D.D. Holm. Fluctuation effects on 3D Lagrangian mean and Eulerian mean fluid motion. *Physica D*, 133:215–269, 1999.
- [66] J. Hong and C. Li. Multi-symplectic Runge-Kutta methods for nonlinear Dirac equations. *J. Comput. Phys.*, 211:448–472, 2006.
- [67] J. Hong, H. Liu, and G. Sun. The multi-symplecticity of partitioned Runge-Kutta methods for Hamiltonian PDEs. Technical report, Chinese Academy of Sciences, Beijing, 2004.
- [68] J. Hong and Y. Liu. A novel numerical approach to simulating nonlinear Schrödinger equations with varying coefficients. *Appl. Math. Lett.*, 16:759–765, 2003.
- [69] J. Hong and Y. Liu. Multisymplecticity of the centred box scheme for a class of Hamiltonian PDEs and an application to quasi-periodically solitary waves. *Math. Comput. Modelling*, 39:1035–1047, 2004.
- [70] J. Hong and M.Z. Qin. Multisymplecticity of the centred box discretization for Hamiltonian PDEs with $m \geq 2$ space dimensions. *Appl. Math. Lett.*, 15:1005–1011, 2002.
- [71] L.-Y. Huang, W.-P. Zeng, and M.Z. Qin. A new multi-symplectic scheme for nonlinear "good" Boussinesq equation. *J. Comp. Math.*, 21:703–714, 2003.
- [72] P.E. Hydon. Multisymplectic conservation laws for differential and differential-difference equations. *Proc. R. Soc. Lond. A*, 461:1627–1637, 2005.
- [73] J.M Hyman and M. Shashkov. Natural discretizations for the divergence, gradient, and curl of logically rectangular grids. *Comp. & Math. with Applic.*, 33:81–104, 1997.
- [74] A.L. Islas, D.A. Karpeev, and C.M. Schober. Geometric integrators for the nonlinear Schrödinger equation. *J. Comput. Phys.*, 173:116–148, 2001.

- [75] A.L. Islas and C.M. Schober. On the preservation of phase space structure under multisymplectic discretization. *J. Comput. Phys.*, 197:585–609, 2004.
- [76] A.L. Islas and C.M. Schober. Backward error analysis for multisymplectic discretizations of Hamiltonian PDEs. *Math. Comp. Simul.*, 69:290–303, 2005.
- [77] S. Jiménez. Derivation of the discrete conservation laws for a family of finite difference schemes. *Applied Mathematical Computation*, 64:13, 1994.
- [78] C. Kane, J.E. Marsden, and M. Ortiz. Symplectic-energy-momentum preserving variational integrators. *J. Math. Phys.*, 40:3353–3371, 1999.
- [79] H.B. Keller. A new difference scheme for parabolic problems. In *Numerical Solution of Partial Differential Equations, II (SYNSPADE 1970)*, pages 327–350. Academic Press, New York, 1971.
- [80] F. Keng and M.Z. Qin. The symplectic method for the computation of Hamiltonian equations. In Y.L. Zhu and B.Y. Guo, editors, *Lecture Notes in Mathematics*, volume 1297, pages 1–37. Springer-Verlag Berlin, 1987.
- [81] S. Kournabaeva and S. Shkoller. A variational approach to second-order multisymplectic field theories. *J. Geom. Phys.*, 35:333–366, 2000.
- [82] J.K. Lawson. A frame bundle generalization of multisymplectic geometry. *Rep. Math. Phys.*, 45:183–205, 2000.
- [83] T.D. Lee. Can time be a discrete dynamical variable? *Phys. Lett. B*, 122:217–220, 1982.
- [84] T.D. Lee. Difference equations and conservation laws. *J. Statis. Phys.*, 46:843–860, 1987.
- [85] B. Leimkuhler and S. Reich. *Simulating Hamiltonian Dynamics*. Cambridge University Press, Cambridge, 2005.
- [86] M. De León and D.M. de Diego. Variational integrators and time-dependent Lagrangian systems. *Rep. Math. Phys.*, 49:183–192, 2002.
- [87] R.J. Leveque. *Finite Volume Methods for Hyperbolic Problems*. Cambridge University Press, New York, 2002.
- [88] A. Lew, J.E. Marsden, M. Ortiz, and M. West. Asynchronous variational integrators. *Arch. Rat. Mech. Anal*, 167:85–146, 2003.
- [89] A. Lew, J.E. Marsden, M. Ortiz, and M. West. Variational time integrators. *Int. J. Numer. Meth. Eng.*, 60:153–212, 2004.
- [90] C.W. Li and M.Z. Qin. A symplectic difference scheme for the infinite dimensional Hamiltonian system. *J. Comput. Appl. Math.*, 6:164–174, 1988.
- [91] S. Li and L. Vu-Quoc. Finite difference calculus invariant structure of a class of algorithms for the nonlinear Klein-Gordon equation. *SIAM J. Numer. Anal.*, 32(6):1839–1875, 1995.
- [92] T. Liu and M.Z. Qin. Multisymplectic geometry and multisymplectic Preissman scheme for the KP equation. *J. Math. Phys.*, 43:4060–4077, 2002.

- [93] L.B. Lucy. A numerical approach to the testing of the fission hypothesis. *Astron. J.*, 82:1013–1024, 1977.
- [94] Q. Ma, J. Izaguirre, and R.D. Skeel. Verlet-I/r-RESPA is limited by nonlinear stability. *SIAM J. Sci. Comput.*, 24:1951–1973, 2003.
- [95] F. Maggi and M. Morini. A γ -convergence result for variational integrators of quadratic Lagrangians. *ESIAM: Control, Optim. Calc. Var.*, 10:656–665, 2004.
- [96] M. Mandziuk and T. Schlick. Resonance in the dynamics of chemical systems simulated by the implicit-midpoint scheme. *Chem. Phys. Lett.*, 237:525–535, 1995.
- [97] E.L. Mansfield and P.E. Hydon. Difference forms. Technical report, Institute of Mathematics, University of Kent, 2004.
- [98] J.E. Marsden, G.P. Patrick, and S. Shkoller. Multi-symplectic geometry, variational integrators, and nonlinear PDEs. *Comm. Math. Phys.*, 199:351–395, 1999.
- [99] J.E. Marsden, S. Pekarsky, S. Shkoller, and M. West. Variational methods, multisymplectic geometry and continuum mechanics. *J. Geom. Phys.*, 38:253–284, 2001.
- [100] J.E. Marsden and T. Ratiu. *Introduction to Mechanics and Symmetry*. Springer-Verlag, New York, 2nd edition, 1998.
- [101] J.E. Marsden and S. Shkoller. Multi-symplectic geometry, covariant Hamiltonians and water waves. *Math. Proc. Camb. Phil. Soc.*, 125:553–575, 1999.
- [102] J.E. Marsden and M. West. Discrete mechanics and variational integrators. *Acta Numerica*, 10:357–514, 2001.
- [103] R.I. McLachlan. Explicit Lie-Poisson integration and the Euler equations. *Physical Review Letters*, 71:3043–3046, 1993.
- [104] R.I. McLachlan. Symplectic integration of Hamiltonian wave equations. *Numer. Math.*, 66:465–492, 1994.
- [105] R.I. McLachlan and G.R.W. Quispel. Splitting methods. *Acta Numerica*, 11:341–434, 2002.
- [106] R.I. McLachlan, G.R.W. Quispel, and N. Robidoux. Geometric integration using discrete gradients. *Phil Trans. Roy. Soc. A*, 357:1021–1046, 1999.
- [107] B.E. Moore. *Geometric Integration of Multi-Symplectic Hamiltonian PDEs*. PhD Thesis, University of Surrey, 2003.
- [108] B.E. Moore and S. Reich. Backward error analysis for multi-symplectic integration methods. *Numerische Mathematik*, 95:625–652, 2003.
- [109] B.E. Moore and S. Reich. Multi-symplectic integrators for Hamiltonian PDEs. *Future Generation Computer Systems*, 19:395–402, 2003.
- [110] P.J. Morrison. Hamiltonian description of the ideal fluid. *Rev. Modern Phys.*, 70:467–521, 1998.
- [111] K.W. Morton and D.F. Mayers. *Numerical Solution of Partial Differential Equations*. Cambridge University Press, Cambridge, 2nd edition, 2005.

- [112] S. Müller and M. Ortiz. On the γ -convergence of discrete dynamics and variational integrators. *J. Nonl. Sci.*, 14:279–296, 2004.
- [113] A.I. Neishtadt. The separation of motions in systems with rapidly rotating phase. *J. Appl. Math. Mech.*, 48:133–139, 1984.
- [114] L.K. Norris. Generalized symplectic geometry on the frame bundle of a manifold. *Proc. Symp. Pure Math.*, 54:435–465, 1993.
- [115] M. Oliver, M. West, and C. Wulff. Approximate momentum conservation for spatial semidiscretizations of nonlinear wave equations. *Numer. Math.*, 97:493–535, 2004.
- [116] P.J. Olver. *Applications of Lie Groups to Differential Equations*. Springer-Verlag, New York, 1986.
- [117] A. Preissman. Propagation des intumescences dan les canaux et rivières. In *First Congress French Association for Computation*. Grenoble, 1961.
- [118] S. Reich. Backward error analysis for numerical integrators. *SIAM J. Numer. Anal.*, 36:475–491, 1999.
- [119] S. Reich. Finite volume methods for multi-symplectic PDEs. *BIT*, 40:559–582, 2000.
- [120] S. Reich. Multi-symplectic Runge-Kutta collocation methods for Hamiltonian wave equations. *J. Comput. Phys.*, 157:473–499, 2000.
- [121] S. Reich. Linearly implicit time-stepping methods for numerical weather prediction. Technical report, Universität Potsdam, Institut für Mathematik, 2005.
- [122] R. Salmon. Practical use of Hamilton’s principle. *J. Fluid Mech.*, 132:431–444, 1983.
- [123] R. Salmon. *Lectures on Geophysical Fluid Dynamics*. Oxford University Press, Oxford, 1999.
- [124] R. Salmon. A general method for conserving quantities related to potential vorticity in numerical models. *Nonlinearity*, 18:R1–R16, 2005.
- [125] J.M. Sanz-Serna and M.P. Calvo. *Numerical Hamiltonian Problems*. Chapman & Hall, London, 1994.
- [126] D.J. Saunders and M. Crampin. On the Legendre map in higher-order field theories. *J. Phys. A: Math. Gen.*, 23:3169–3182, 1990.
- [127] M. Schemann and F.A. Bornemann. An adaptive Rothe method for the wave equation. *Comput. Visual Sci.*, 1:137–144, 1998.
- [128] M. Shashkov. *Conservative finite-diffence methods on general grids*. CRC Press, Boca Raton, FL, 1996.
- [129] T.G. Shepherd. Symmetries, conservation laws, and Hamiltonian structure in geophysical fluid dynamics. *Adv. Geophys.*, 32:287–338, 1990.
- [130] J.C. Simo, N. Tarnow, and K.K. Wong. Exact energy-momentum conserving algorithms and symplectic schemes for nonlinear dynamics. *Comput. Methods Appl. Mech. Engrg.*, 100:63–116, 1992.

- [131] R.D. Skeel and K. Srinivas. Nonlinear stability analysis of area preserving integrators. *SIAM J. Numer. Anal.*, 38:129–148, 2000.
- [132] A. Staniforth, N. Wood, and S. Reich. A time-staggered semi-Lagrangian discretization of the shallow-water equations. Technical report, UK MetOffice and University of Potsdam, in preparation.
- [133] W. Strauss and L. Vázquez. Numerical solution of a nonlinear Klein-Gordon equation. *J. Comput. Phys.*, 28:271, 1978.
- [134] H. Su and M.-Z. Qin. Multisymplectic geometry method for Maxwell’s equations and multi-symplectic scheme. Technical report, arXiv.org math-ph/0302058, 2005.
- [135] J.-Q. Sun and M.Z. Qin. Multi-symplectic methods for the coupled 1D nonlinear Schrödinger equation. *Comput. Phys. Comm.*, 155:221–235, 2003.
- [136] Y. Sun and M.Z. Qin. Variational integrators for higher-order differential equations. *J. Comput. Math.*, 21:135–144, 2003.
- [137] Y.-J. Sun and M.Z. Qin. Construction of multisymplectic schemes of any finite order for modified wave equations. *J. Math. Phys.*, 41:7854–7868, 2000.
- [138] Y.-J. Sun and M.Z. Qin. A multi-symplectic scheme for RLW equation. *J. Comput. Math.*, 22:611–621, 2004.
- [139] L.N. Trefethen. Stability of finite-difference models containing two boundaries or interfaces. *Math. Comp.*, 45:279–300, 1985.
- [140] R. Vichnevetsky and J.B. Bowles. *Fourier analysis of numerical approximations of hyperbolic equations*. SIAM, Philadelphia, 1982.
- [141] L. Vu-Quoc and S. Li. Invariant-conserving finite difference algorithms for the nonlinear Klein-Gordon equation. *Comp. Meth Appl. Mech. Eng.*, 107:341–391, 1993.
- [142] Y. Wang and B. Wang. High-order multi-symplectic schemes for the nonlinear Klein-Gordon equation. *Appl. Math. Comp.*, 166:608–632, 2005.
- [143] Y. Wang, B. Wang, and M.Z. Qin. Numerical implementation of the multisymplectic Preissman scheme and its equivalent schemes. *Appl. Math. Comput.*, 149:299–326, 2004.
- [144] Y. Wang, B. Wang, H. Yang, and Y. Wang. An artificial boundary condition for the multi-symplectic Preissman scheme. *J. Phys. Soc. Japan*, 73:1457–1463, 2004.
- [145] Y.S. Wang and M.Z. Qin. Multisymplectic geometry and multisymplectic scheme for the nonlinear Klein-Gordon equation. *J. Phys. Soc. Japan*, 70:653–661, 2001.
- [146] Y.S. Wang and M.Z. Qin. Multisymplectic schemes for the nonlinear Klein-Gordon equation. *Math. Comput. Modelling*, 36:963–977, 2002.
- [147] G.B. Whitham. *Linear and Nonlinear Waves*. Wiley-Interscience, New York, 1974.
- [148] B.A. Wingate. The maximum allowable time step for the shallow water α model and its relation to time-implicit differencing. *Monthly Weather Rev.*, 132:2719–2731, 2004.

- [149] N. Wood, A. Staniforth, and S. Reich. An improved regularization for time-staggered discretization and its link to the semi-implicit method. *Atmos. Sci. Lett.*, in press, 2006.
- [150] K.S. Yee. Numerical solution of initial boundary value problems involving Maxwell's equations in isentropic coordinates. *IEEE Trans. Antennas Propag.*, 14:302–307, 1966.
- [151] V. Zeitlin. Finite-mode analogs of 2D ideal hydrodynamics: Coadjoint orbits and local canonical structure. *Physica D*, 49:353–362, 1991.
- [152] P.-F. Zhao and M.-Z. Qin. Multisymplectic geometry and multisymplectic Preissman scheme for the KdV equation. *J. Phys. A: Math. Gen.*, 33:3613–3626, 2000.
- [153] L. Zhen, Y. Bai, Q. Li, and K. Wu. Symplectic and multisymplectic schemes with the simple finite element method. *Phys. Lett. A*, 314:443–455, 2003.